

F211 – 3U CompactPCI® Quad Fast Ethernet Interface

- 4 HP 32-bit/33-MHz CompactPCI®
- 4 full-duplex or half-duplex channels
- 10Base-T and 100Base-TX physical layer
- Fully integrated to comply with IEEE802.3u
- 1500 V isolation voltage
- -40 to +85°C with qualified components

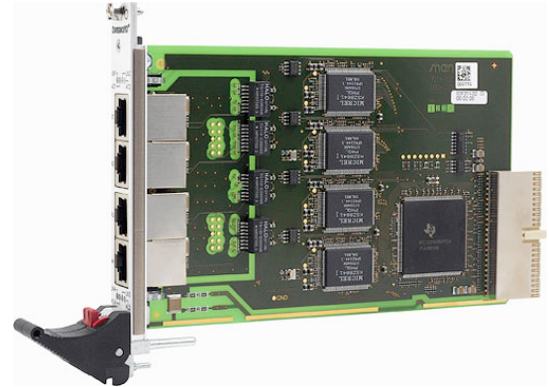

The F211 is a single Eurocard CompactPCI® networking controller that needs only one slot on the CompactPCI® bus.

The four Fast Ethernet channels on one card occupy four individual MAC/IP addresses. They support full-duplex or half-duplex with 10Base-T and 100Base-TX physical layers for distances up to 100 m. Featuring auto-negotiation, collision and link detection the maximum data transfer rate per channel is 200 Mbit/s

with full-duplex operation.

The Ethernet channels on the F211 can be used individually as well as in redundant mode for high-availability systems by using some of the Ethernet ports in parallel.

The F211 has been designed for rugged and mobile applications with demand for multiple network controllers such as firewalls, gateways, routers, or as a fieldbus data concentrator based on industrial Ethernet. The F211 is qualified for extended operation temperature and prepared for conformal coating for use in harsh and mobile environments.

Diagram

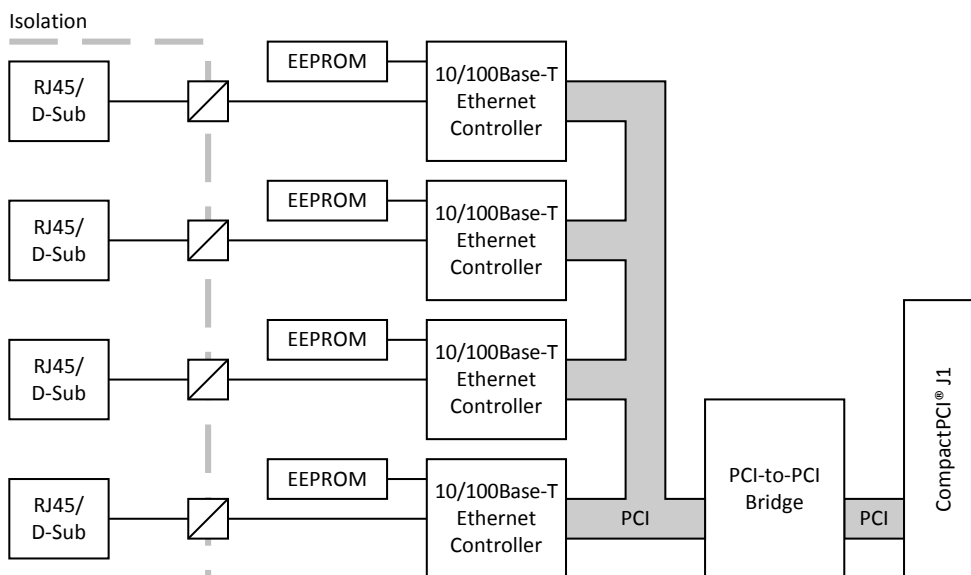

Technical Data

Ethernet Interfaces	<ul style="list-style-type: none"> ■ Four 10/100Base-TX interfaces ■ Four Micrel KSZ8841 controllers ■ IEEE802.3x support <ul style="list-style-type: none"> □ Full-duplex flow control □ Half-duplex back pressure collision flow control ■ Internal 8KB RX/TX FIFO buffers ■ Auto-negotiation and auto MDIX crossover ■ LinkMD[®] cable diagnostics to determine cable length, cable faults and distance to fault ■ Media Access Control (MAC) addresses stored in onboard serial EEPROMs ■ 4x2 status LEDs to signal link status, activity, speed and collision
Front Connections	<ul style="list-style-type: none"> ■ Four standard 8-pin RJ45 receptacle connectors
CompactPCI[®] Bus	<ul style="list-style-type: none"> ■ Compliance with CompactPCI[®] Core Specification PICMG 2.0 R3.0 ■ Peripheral slot ■ 32-bit/33-MHz PCI-to-PCI bridge ■ V(I/O): +3.3V or +5V (Universal Board)
Electrical Specifications	<ul style="list-style-type: none"> ■ Isolation voltage: 1000V between Ethernet links and 1500V between Ethernet links and shield or ground ■ Supply voltage/power consumption: <ul style="list-style-type: none"> □ +3.3V (-3%/+5%), 1A max. ■ MTBF: 875,481h @ 40°C according to IEC/TR 62380 (RDF 2000)
Mechanical Specifications	<ul style="list-style-type: none"> ■ Dimensions: conforming to CompactPCI[®] specification for 3U boards ■ Weight: 115g (standard version)
Environmental Specifications	<ul style="list-style-type: none"> ■ Temperature range (operation): <ul style="list-style-type: none"> □ -40..+85°C (qualified components) □ Airflow: min. 10m³/h ■ Temperature range (storage): -40..+85°C ■ Relative humidity (operation): max. 95% non-condensing ■ Relative humidity (storage): max. 95% non-condensing ■ Altitude: -300m to + 3,000m ■ Shock: 15g/11ms ■ Bump: 10g/16ms ■ Vibration (sinusoidal): 2g/10..150Hz ■ Conformal coating on request
Safety	<ul style="list-style-type: none"> ■ PCB manufactured with a flammability rating of 94V-0 by UL recognized manufacturers
EMC	<ul style="list-style-type: none"> ■ Tested according to EN 55022 (radio disturbance), IEC1000-4-2 (ESD) and IEC1000-4-4 (burst)
Software Support	<ul style="list-style-type: none"> ■ Drivers for Linux and Windows[®] from Micrel ■ Driver for QNX[®] from QNX[®] ■ For more information on supported operating system versions and drivers see Downloads.

Configuration & Options

Standard Configurations

Article No.	Channels	Connectors	Front Panel	Operation Temperature
02F211-00	4	4 RJ45	4HP	-40..+85°C

Options

Front Connection	<ul style="list-style-type: none"> ■ 4 Ethernet channels on 4 D-Sub connectors, 2-slot front panel (8 HP) ■ 4 Ethernet channels on 2 D-Sub connectors (shared), 1-slot front panel (4 HP) ■ 4 Ethernet channels on 4 M12 receptacle connectors, 2-slot front panel (8 HP)
Cooling Concept	<ul style="list-style-type: none"> ■ Also available with conduction cooling in MEN CCA frame

Please note that some of these options may only be available for large volumes. Please ask our sales staff for more information.

Ordering Information

Standard F211 Models	02F211-00	4 100Base-T Ethernet interfaces, 4 RJ45 connectors at front, -40..+85°C with qualified components
-----------------------------	------------------	---

Software: Linux	<p>This product is designed to work under Linux. See below for potentially available separate software packages from MEN.</p> <p>For a Linux driver package supporting the Micrel KSZ8841 Ethernet controller, please refer to www.micrel.com/index.php/en/component/joomla/article/18-controllers/5-ksz8841-pmql.html. We highly recommend a kernel newer than 2.6.32.</p>	
------------------------	--	--

Software: Windows®	<p>This product is designed to work under Windows®. See below for potentially available separate software packages from MEN.</p>	
	13T024-70	Windows® Ethernet driver for F211/F302 (Micrel KSZ8841 MAC) with option to disable hardware checksumming

Software: QNX®	<p>This product is designed to work under QNX®. For details regarding supported/unsupported board functions please refer to the corresponding software data sheets.</p> <p>For a QNX® 6.3.0SP3 and QNX® 6.3.2 driver package supporting the Micrel KSZ8841 Ethernet controller, please refer to the latest QNX® network driver update: www.qnx.com/download/feature.html?programid=17094. The devn-micrel8841.so driver integrated there supports the F211 Ethernet controller. Starting from QNX® 6.4 this driver is directly included in the distribution.</p>	
-----------------------	---	--

For operating systems not mentioned here [contact MEN sales](#).

Documentation	<p>Compare Chart 3U CompactPCI® / PlusIO CPU cards » Download</p> <p>Compare Chart 3U CompactPCI® / PlusIO peripheral cards » Download</p>	
	20F211-00	F211 User Manual

Contact Information

Germany

MEN Mikro Elektronik GmbH
Neuwieder Straße 3-7
90411 Nuremberg
Phone +49-911-99 33 5-0
Fax +49-911-99 33 5-901

info@men.de
www.men.de

France

MEN Mikro Elektronik SA
18, rue René Cassin
ZA de la Châtelaine
74240 Gaillard
Phone +33 (0) 450-955-312
Fax +33 (0) 450-955-211

info@men-france.fr
www.men-france.fr

USA

MEN Micro, Inc.
24 North Main Street
Ambler, PA 19002
Phone (215) 542-9575
Fax (215) 542-9577

sales@menmicro.com
www.menmicro.com

The date of issue stated in this data sheet refers to the Technical Data only. Changes in ordering information given herein do not affect the date of issue. All brand or product names are trademarks or registered trademarks of their respective holders.

MEN is not responsible for the results of any actions taken on the basis of information in the publication, nor for any error in or omission from the publication.

MEN expressly disclaims all and any liability and responsibility to any person, whether a reader of the publication or not, in respect of anything, and of the consequences of anything, done or omitted to be done by any such person in reliance, whether wholly or partially, on the whole or any part of the contents of the publication.

The correct function of MEN products in mission-critical and life-critical applications is limited to the environmental specification given for each product in the technical user manual. The correct function of MEN products under extended environmental conditions is limited to the individual requirement specification and subsequent validation documents for each product for the applicable use case and has to be agreed upon in writing by MEN and the customer. Should the customer purchase or use MEN products for any unintended or unauthorized application, the customer shall indemnify and hold MEN and its officers, employees, subsidiaries, affiliates, and distributors harmless against all claims, costs, damages, and expenses, and reasonable attorney fees arising out of, directly or indirectly, any claim or personal injury or death associated with such unintended or unauthorized use, even if such claim alleges that MEN was negligent regarding the design or manufacture of the part.

In no case is MEN liable for the correct function of the technical installation where MEN products are a part of.

Copyright © 2013 MEN Mikro Elektronik GmbH. All rights reserved.