

Features

- 1-channel
- 24 V DC supply voltage
- Input according to NAMUR in acc. with EN 60947-5-6
- 2 relay outputs
- LB/SC monitoring
- Up to SIL2 acc. to IEC 61508

Function

The isolated switch amplifier transfers digital signals of sensors per EN 60947-5-6 (NAMUR) and mechanical alarm contacts from the hazardous area.

The line fault detection (LB, SC) of the field circuit can be deactivated with switch 3.

The external faults are indicated according to NAMUR NE44 by a red flashing LED and a LB/SC collective error message is in addition transmitted to the power feed module via the Power Rail. In the event of fault all relays de-energized. Relay output II can optionally be assigned to the relay output I or the error message with the aid of switch S2. The mode of operation can be adjusted with switch S1.

The intrinsically safe input is safely isolated from the output and the power supply in accordance with EN 50020.

Application

For detection of positions, final positions and switching states in the hazardous area.

Composition

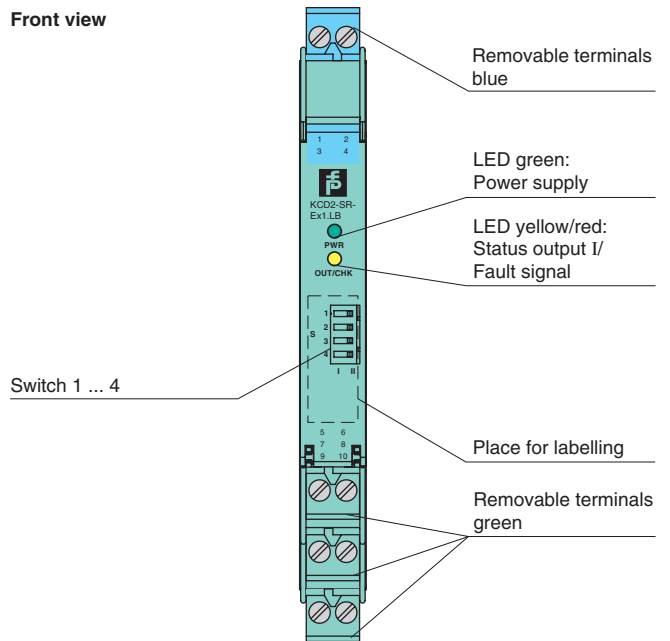

Connection

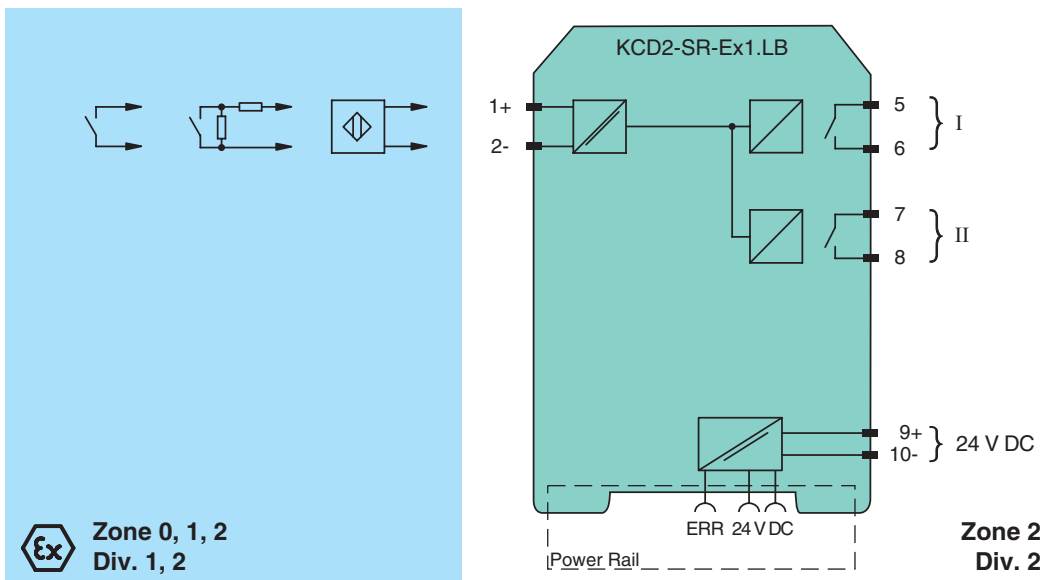

Release date 2007-10-17 17:09 Date of issue 2007-10-17 185532_ENG.xml

| | |
|---|---|
| Supply | |
| Connection | Power Rail or terminals 9+, 10- |
| Rated voltage | 19 ... 30 V DC |
| Ripple | ≤ 10 % |
| Rated current | ≤ 30 mA |
| Power loss | ≤ 500 mW |
| Power consumption | ≤ 500 mW |
| Input | |
| Connection | terminals 1+, 2- |
| Rated values | acc. to EN 60947-5-6 (NAMUR) |
| Open-circuit voltage/short-circuit current | approx. 10 V DC / approx. 8 mA |
| Switching point/Switching hysteresis | 1.2 ... 2.1 mA / approx. 0.2 mA |
| Line fault detection | breakage I ≤ 0.1 mA , short-circuit I ≥ 6.5 mA |
| Pulse/Pause ratio | ≥ 20 ms / ≥ 20 ms |
| Output | |
| Connection | output I: terminals 5, 6 ; output II: terminals 7, 8 |
| Output I | signal ; relay |
| Output II | signal or error message ; relay |
| Contact loading | 253 V AC/2 A/cos φ > 0.7; 126.5 V AC/4 A/cos φ > 0.7; 30 V DC/2 A resistive load |
| Minimum switch current | 2 mA / 24 V DC |
| Energized/de-energized delay | ≤ 20 ms / ≤ 20 ms |
| Mechanical life | 10 ⁷ switching cycles |
| Transfer characteristics | |
| Switching frequency | ≤ 10 Hz |
| Electrical isolation | |
| Output/power supply | reinforced insulation acc. to IEC 61140, rated insulation voltage 300 V _{eff} |
| Output/output | reinforced insulation acc. to IEC 61140, rated insulation voltage 300 V _{eff} |
| Indicators/settings | |
| Labelling | place for labelling on the front side |
| Directive conformity | |
| Electromagnetic compatibility | |
| Directive 89/336/EC | EN 61326 |
| Low voltage | |
| Directive 73/23/EEC | EN 50178 |
| Conformity | |
| Electromagnetic compatibility | NE 21 |
| Protection degree | IEC 60529 |
| Protection against electric shock | IEC 61140 |
| Ambient conditions | |
| Ambient temperature | -20 ... 60 °C (253 ... 333 K) |
| Mechanical specifications | |
| Protection degree | IP20 |
| Mass | approx. 100 g |
| Dimensions | 12.5 x 114 x 119 mm (0.5 x 4.5 x 4.7 in) , housing type A2 |
| Data for application in conjunction with hazardous areas | |
| EC-Type Examination Certificate | BASEEFA 06 ATEX 0092 , for additional certificates see www.pepperl-fuchs.com |
| Group, category, type of protection | ⊕ II (1)GD [Ex ia] IIC; [Ex ia D] [circuit(s) in zone 0/1/2/20/21/22] I (M1) [Ex ia] I |
| Input | Ex ia/Ex ia D |
| Voltage U _o | 10.5 V |
| Current I _o | 17.1 mA |
| Power P _o | 45 mW (linear characteristic) |
| Supply | |
| Safety maximum voltage U _m | 253 V AC (Attention! U _m is no rated voltage.) |
| Output I and II | |
| Safety maximum voltage U _m | 253 V AC (Attention! U _m is no rated voltage.) |
| Contact loading | 253 V AC/2 A/cos φ > 0.7; 126.5 V AC/4 A/cos φ > 0.7; 30 V DC/2 A resistive load |
| Statement of conformity | |
| Group, category, type of protection, temperature classification | ⊕ II 3G Ex nA nC IIC T4 X |
| Output I and II | |
| Contact loading | 50 V AC/2 A/cos φ > 0.7; 30 V DC/2 A resistive load |
| Electrical isolation | |
| Input/output | safe electrical isolation acc. to EN 50020, voltage peak value 375 V |

Release date 2007-10-17 17:09 Date of issue 2007-10-17 185532_ENG.xml

| | |
|----------------------------|--|
| Input/power supply | safe electrical isolation acc. to EN 50020, voltage peak value 375 V |
| Directive conformity | |
| Directive 94/9 EC | EN 60079-0, EN 50020, IEC 61241-11, IEC 61241-0, EN 60079-26, EN 60079-15 |
| General information | |
| Supplementary information | EC-Type Examination Certificate, Statement of Conformity, Declaration of Conformity and instructions have to be observed. For information see www.pepperl-fuchs.com . |

Configuration

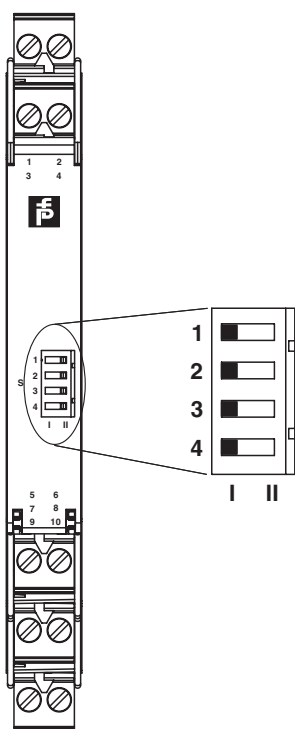

Switch position

| S | Function | | Position |
|---|--|--|----------|
| 1 | Mode of operation Output I (relay) energized | with high input current | I |
| | | with low input current | II |
| 2 | Assignment Output II (relay) | switching state like relay I | I |
| | | fault signal output (de-energized if fault) | II |
| 3 | Lead fault detection | ON | I |
| | | OFF | II |
| 4 | no function | | |

Operating status

| Control circuit | Input signal |
|---|--------------------|
| Initiator high impedance/ contact opened | low input current |
| Initiator low impedance/ contact closed | high input current |
| Lead breakage, lead short-circuit | Lead fault |

Factory settings: switch 1, 2, 3 and 4 in position I

Accessories

Power feed modules KFD2-EB2...

The power feed module is used to supply the devices with 24 V DC via the Power Rail. The fuse-protected power feed module can supply up to 100 individual devices depending on the power consumption of the devices. A galvanically isolated mechanical contact uses the Power Rail to transmit collective error messages.

Power Rail UPR-03

The Power Rail UPR-03 is a complete unit consisting of the electrical inset and an aluminium profile rail 35 mm x 15 mm. To make electrical contact, the devices are simply engaged.

The Power Rail must not be fed via the device terminals of the individual devices!