

Industrial Operator Panels

Software Introduction		1-2
WOP-2000 Selection Guide		1-4
WOP-2000 Series		
WOP-2035V	3.5" QVGA Operator Panel with PM Designer 2.0 Software	1-6
WOP-2057V	5.7" QVGA Operator Panel with PM Designer 2.0 Software	1-8
WOP-2070V	7" WVGA Operator Panel with PM Designer 2.0 Software	1-10
WOP-2080V	8" SVGA Operator Panel with PM Designer 2.0 Software	1-12
WOP-2104V	10.4" SVGA Operator Panel with PM Designer 2.0 Software	1-14
WOP-2121V	12.1" SVGA Operator Panel with PM Designer 2.0 Software	1-16
Supported PLC Controllers	Communication Port (COM)	1-18
Supported PLC Controllers	Communication Port (Ethernet)	1-20

To view all of Advantech's Industrial Operator Panels, please visit www.advantech.com/products.

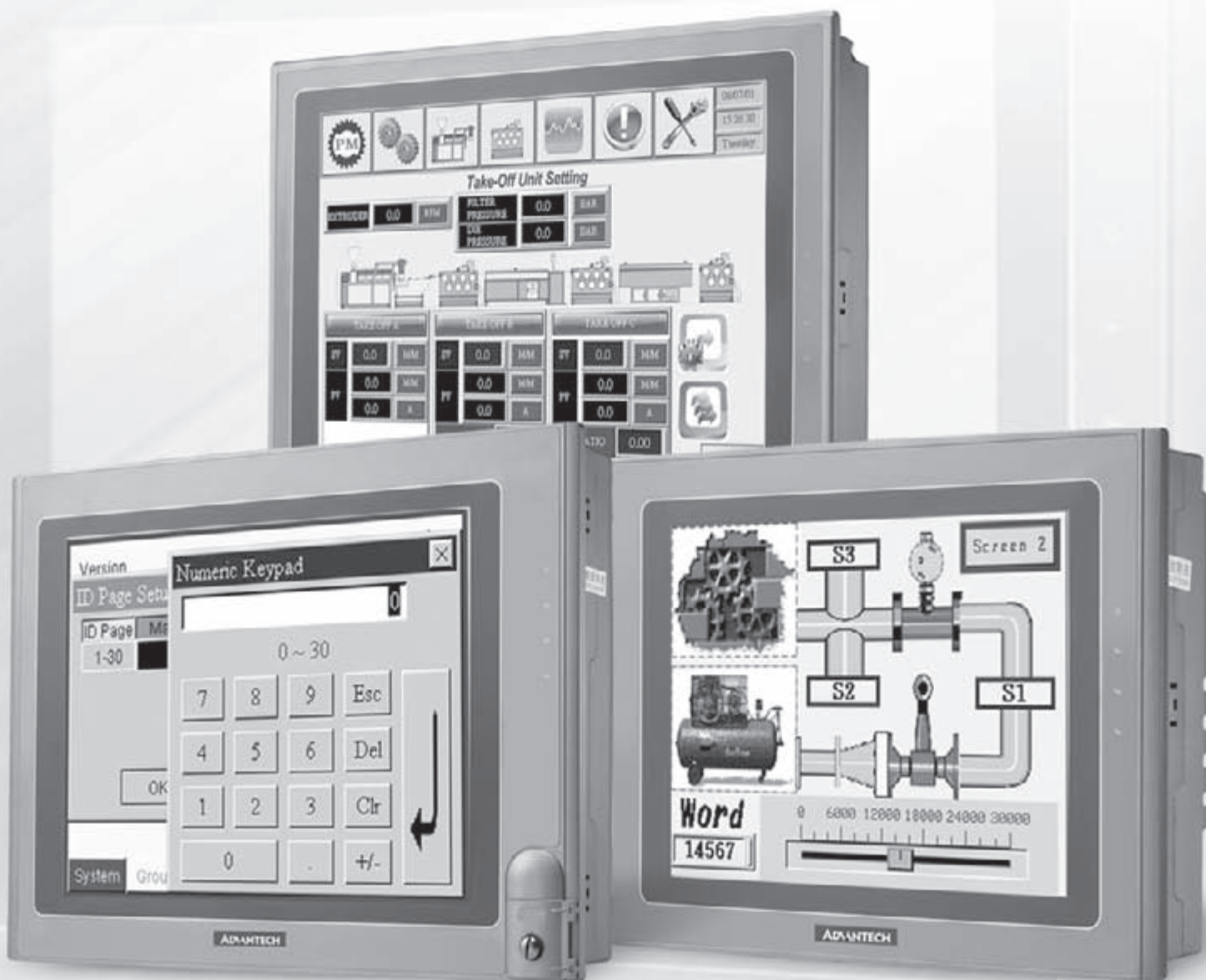

PM Designer 2.0

HMI Runtime Development Software

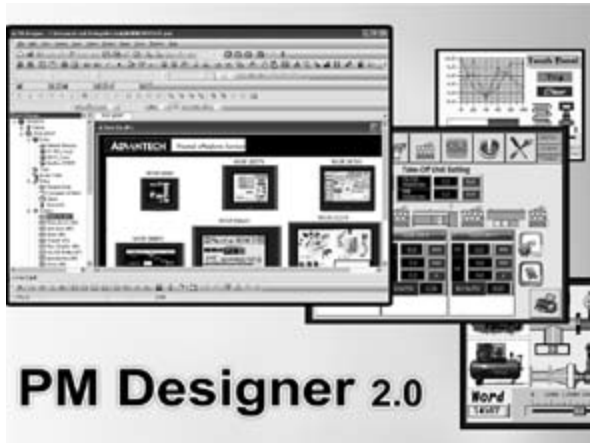

Software Features

- Allows users to manage multiple HMI applications in one project
- Allows users to switch multi-language UI dynamically, with Unicode and multilingual screen text supported
- Provides password protection of designs, macros and upload/download operations
- Supports vertical, horizontal screen displays
- Enables one design to fit all HMI models
- Provides index registers for modifying device addresses at runtime
- Collects data from many devices with various methods
- Supports various data acquisition and trend presentation
- Operation log helps the review and investigation of important events
- Allows to download the runtime data using serial port, Ethernet port, USB client port at HMI and Micro-SD.
- Allows to use the USB Memory Sticker for the trouble-free update of the application
- Supports over 250 industrial communication protocols such as SIMATIC S7-1200, BACNet MSTP/BACNet IP etc. and the driver list is growing

Introduction

PM Designer is powerful yet intuitive software to create total solutions for WOP series Human Machine Interface products. PM Designer is proven in many application fields and is an easy to use integrated development tool. The features include solution-oriented screen objects, high-end vector graphics, Windows fonts for multi-language applications, recipes, alarms, data loggers and operation logging. PM Designer also includes online/offline simulation and other utility programs such as Data Transfer Helper (DTH); recipes editors and text editors.

WOP runtime, a part of PM Designer, guarantees reliability and performance of WOP Series HMI because of the minimum system overhead, high communication data rates, sub-second screen switching, and 24/7 operation. Our fast response software team adds new functions, communication drivers and solutions to the software all the time to meet dynamic needs.

System Requirements

Minimum OS Requirements:

- Windows 2000 SP4
- Windows XP SP2 (for all flavors of XP such as Home, Media Center, Tablet PC)
- Windows Server 2003
- Windows Vista
- Windows 7

Project Development Steps

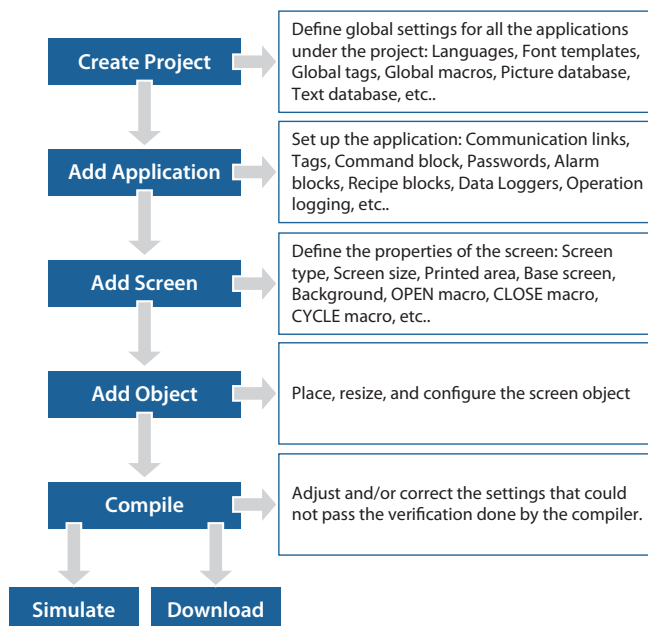

Features

Global Settings and Resources Sharable to all Applications of the Same Project

- Multi-languages (up to 10 languages)
- Font templates (up to 20 fonts for each language, TrueType fonts supported)
- Picture database (BMP, JPG, GIF, WMF), Sound database (WAV), Text Database
- Global Tags
- Global Macros

Plenty of Solution-oriented Screen Objects

- For common HMI needs:
Buttons, Lamps, Message displays, Numeric displays, Numeric entries, Character displays, Character entries, Time displays, Date displays, Bar Graphs, Meters, etc.
- For animation:
Pictures displays, GIF displays, Animated graphics, Dynamic rectangles, Dynamic circles, Pipelines, Circular bar graph, etc.
Color of basic graphic objects (text, lines, rectangles, circles, etc.) changeable
Shape and color of buttons and lamps changeable
- For advanced functions:
Line chart, Scatter chart, Recipe selector, Recipe table, Alarm history display, Active alarm display, Alarm count display, Historic trend graph, Historic data table, Historic event table, Historic line chart, Operation log display, Sub-link table, etc.

Communication Links

The WOP series HMI products can have at most 4 built-in communication ports. The PM Designer software allows you to create up to 4-links and 255 sub-links for one application. More than 250 communication drivers allow 1-to-N (one panel to a wide variety of industrial devices) or N-to-1 (multiple panels to one device) connections.

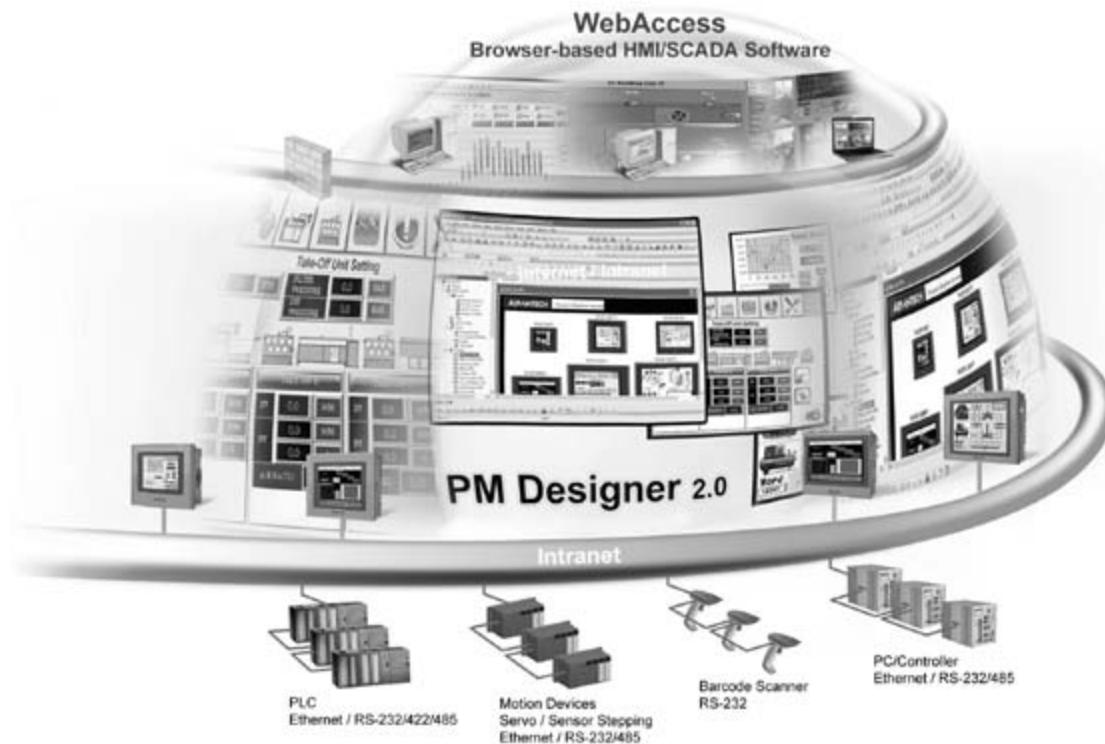

One Design for all Models

The PM Designer software provides the auto resizing function to resize all the objects so they can fit the new screen size when you change the HMI model. It makes the HMI model changes done in seconds.

Easy to Accumulate/Reuse Design Achievements

- Import/Export Function
The PM Designer software provides the simple method for importing and exporting data between applications or projects. The data includes Language setting, Font templates, Pictures, Sounds, Text, Tags, Macros, Application, Screen, Alarm messages, Control block and status word settings, etc.
- Object Library
The object library makes configuring, managing and sharing the user-defined objects easier. It contains default objects, common objects, object groups and global objects.

Enhanced Intellectual Property (IP) Protection

The PM Designer strengthens the IP protection by password with different levels. You can set the password to protect project, password table and global macros. You can also use up to 9 levels of passwords to secure the operations and restrict access to the objects. You can choose to prohibit uploading and copying of the panel application stored in the HMI unit.

Recipe

Distinguish from the conventional recipe operations, the PM Designer provides complete solutions to deal with recipes:

- Supports up to 16 recipe blocks
- Provides recipe selector for selecting a recipe and recipe table for displaying and modifying recipe data at runtime
- Provides RecipeEditor, an independent executable program, to view and edit recipe data saved in a binary file on PC
- Able to notify a bit when the recipe operations are performed successfully to prevent data loss

Data Collected into a CSV/TXT file

Allows to save/load collected data to/from CSV or TXT files. Those two standard file formats allows one to easily manipulate data on PC.

Alarm

The PM Designer supports up to 16 discrete alarm blocks and up to 16 analog alarm blocks. It provides alarm history display, active alarm display, alarm count display and alarm marquee to display alarms in the application.

Macros, an easy-to-learn language with simple syntax

Application developers may program their own solutions using the macro commands for:

- Operations that are not supported in a standard object or feature of PM Designer
- Sequential, Interactive, Conditional and File operations
- Non-linear data conversions
- Data exchange between two controllers
- Simple communication drivers
- Hard-to-implement tasks in controllers
- Offloading the burden of controllers to boost their performance

Simplified Architecture

- Real time WYSIWYG screen editor, 8 toolbars and screen manager
- Screen overview that shows the relations among screens of the current application
- Link overview that shows the relations among links of the current application
- Object list that shows the screen objects and the associated I/O address of the current screen
- I/O list that shows all the I/O addresses of the project and their owners
- Compiler to verify, optimize, and build the designs
- Online/offline simulation for design verification
- Data Transfer Helper (DTH), an independent executable program, to help you get/update application data through serial port or Ethernet port
- Text Editor for editing all screen texts in multi-languages

1	Operator Panels
2	Fanless Panel PCs
3	Panel Computers
4	Display Solutions
5	Ethernet Switches
6	Device Servers
7	Serial Comm. Cards
8	Video Surveillance
9	Pre-Configured Systems
10	IPC Chassis
11	SBCs and Backplanes
12	Industrial Motherboards
13	Embedded IPCs
14	Mobile Computers
15	IPC Peripherals
16	DAQ
17	Signal Conditioning
18	USB DAQ

WOP-2000 Selection Guide



Model		WOP-2035V		WOP-2057V	
Ordering Information		WOP-2035V-S1AE	WOP-2035V-N1AE	WOP-2057V-S1AE	WOP-2057V-N1AE
CPU		RISC 32 bits, 70 MHz		RISC 32 bits, 70 MHz	
Battery Backup Memory		128 KB		128 KB	
Flash Memory		4 MB	4 MB	4 MB	4 MB
Operating System		HMI RTOS, PM Designer 2.0		HMI RTOS, PM Designer 2.0	
Display	Type	QVGA TFT LCD		QVGA TFT LCD	
	Size	3.5"		5.7"	
	Max. Resolution	320 x 240		320 x 240	
	Max. Colors	256 colors		256 colors	
	Luminance (cd/m ²)	350		400	
	Viewing Angle (H/V°)	120/100		100/95	
	Backlight Life (hur)	LED, 20,000		LED, 20,000	
Dimming		Adjustable		Adjustable	
Touchscreen		4 wires Analog resistive		4 wires Analog resistive	
Power-On LED		Yes		Yes	
Communication LED		No		COM1 and COM2	
Front USB Access		No		No	
Communication Interface	COM1	RS-232/422/485 (DB9 Female)		RS-232/422/485 (DB9 Female)	
	COM2	RS-422/485 (5-Pins Plug Connector)		RS-232/422/485 (DB9 Male & 5-Pins Plug Connector)	
	COM3	-	-	-	-
	Ethernet (RJ45)	-	10/100-BaseT	-	10/100-BaseT
I/Os	USB Client	-		-	
	USB Host	-		-	
	Micro-SD Slot	-		-	
Power Supply Voltage		24 V _{DC} ±10%		24 V _{DC} ±10%	
Power Consumption		10W		15 W	
Dimension W x H x D (mm)		130 x 106.2 x 45 mm (5.11" x 4.18" x 1.77")		187 x 145.7 x 45 mm (7.36" x 5.73" x 1.77")	
Cut-out Dimensions W x H (mm)		118.5 x 92.5 mm (4.66" x 3.64")		174.5 x 132.5 mm (6.87" x 5.21")	
Front Panel thickness (mm)		6 mm		6 mm	
Net Weight		0.27 kg		0.65 kg	
Operating Temperature		0 ~ 50° C (32 ~ 122° F)		0 ~ 50° C (32 ~ 122° F)	
Storage Temperature		-20 ~ 60° C (-4 ~ 140° F)		-20 ~ 60° C (-4 ~ 140° F)	
Humidity		10 ~ 95% RH @ 40° C, non-condensing		10 ~ 95% RH @ 40° C, non-condensing	
Ingress Protection		Front panel: NEMA4, IP65		Front panel: NEMA4, IP65	
Certification Approval		CE/FCC/BSMI/UL/CCC		CE/FCC/BSMI/UL/CCC	
Page		1-6		1-8	

Selection Guide



WOP-2070V	WOP-2080V	WOP-2104V	WOP-2121V
WOP-2070V-N4AE	WOP-2080V-N4AE	WOP-2104V-N4AE	WOP-2121V-N4AE
RISC 32 bits, 200 MHz	RISC 32 bits, 200 MHz	RISC 32 bits, 200 MHz	RISC 32 bits, 200 MHz
128 KB	128 KB	128 KB	128 KB
16 MB	16 M	16 M	16 M
HMI RTOS, PM Designer 2.0	HMI RTOS, PM Designer 2.0	HMI RTOS, PM Designer 2.0	HMI RTOS, PM Designer 2.0
WVGA TFT LCD	SVGA TFT LCD	SVGA TFT LCD	SVGA TFT LCD
7"	8"	10.4"	12.1"
800 x 480	800 x 600	800 x 600	800 x 600
65,536 colors	65,536 colors	65,536 colors	65,536 colors
300	350	300	350
140/130	140/130	140/120	130/110
LED, 20,000	LED, 50,000	LED, 30,000	CCFL, 30,000
Adjustable	Adjustable	Adjustable	Adjustable
4 wires Analog resistive	4 wires Analog resistive	4 wires Analog resistive	8 wires Analog resistive
Yes	Yes	Yes	Yes
No	COM1, COM2 and COM3	COM1, COM2 and COM3	COM1, COM2 and COM3
No	No	Yes	No
RS-232/422/485 (DB9 Female)	RS-232/422/485 (DB9 Female)	RS-232/422/485 (DB9 Female)	RS-232/422/485 (DB9 Female)
RS-232/422/485 (DB9 Male & 5-Pin Plug Connector)	RS-232/422/485 (DB9 Male & 5-Pins Plug Connector)	RS-232/422/485 (DB9 Male & 5-Pins Plug Connector)	RS-232/422/485 (DB9 Male & 5-Pins Plug Connector)
-	RS-232 (6-Pins Plug Connector)	RS-232 (6-Pins Plug Connector)	RS-232 (6-Pins Plug Connector)
10/100-BaseT	10/100-BaseT	10/100-BaseT	10/100-BaseT
-	Yes	Yes	Yes
Yes	-	-	-
-	-	-	-
24 V _{DC} ±10%	24 V _{DC} ±10%	24 V _{DC} ±10%	24 V _{DC} ±10%
25 W	25 W	25 W	25 W
188 x 143.3 x 40 mm (7.4" x 5.64" x 1.57")	232.5 x 175.8 x 42.9 mm (9.15" x 6.92" x 1.69")	297 x 224 x 52 mm (11.6" x 8.8" x 2.04")	315 x 241 x 54.5 mm (12.4" x 9.48" x 2.14")
174.5 x 132.5 mm (6.87" x 5.21")	221.5 x 164 mm (8.72" x 6.45")	285.5 x 210.5 mm (11.24" x 8.28")	301.5 x 228 mm (11.87" x 8.97")
6 mm	6 mm	6 mm	6 mm
1.0 kg	1.0 kg	1.55 kg	1.55 kg
0 ~ 50° C (32 ~ 122° F)	0 ~ 50° C (32 ~ 122° F)	0 ~ 50° C (32 ~ 122° F)	0 ~ 50° C (32 ~ 122° F)
-20 ~ 60° C (-4 ~ 140° F)	-20 ~ 60° C (-4 ~ 140° F)	-20 ~ 60° C (-4 ~ 140° F)	-20 ~ 60° C (-4 ~ 140° F)
10 ~ 95% RH @ 40° C, non-condensing	10 ~ 95% RH @ 40° C, non-condensing	10 ~ 95% RH @ 40° C, non-condensing	10 ~ 95% RH @ 40° C, non-condensing
Front panel: NEMA4, IP65	Front panel: NEMA4, IP65	Front panel: NEMA4, IP65	Front panel: NEMA4, IP65
CE/FCC/BSMI/UL/CCC	CE/FCC/BSMI/UL/CCC	CE/FCC/BSMI/UL/CCC	CE/FCC/BSMI/UL/CCC
1-10	1-12	1-14	1-16

1

Operator Panels

2

Fanless Panel PCs

3

Panel Computers

4

Display Solutions

5

Ethernet Switches

6

Device Servers

7

Serial Comm. Cards

8

Video Surveillance

9

Pre-Configured Systems

10

IPC Chassis

11

SBCs and Backplanes

12

Industrial Motherboards

13

Embedded IPCs

14

Mobile Computers

15

IPC Peripherals

16

DAQ

17

Signal Conditioning

18

USB DAQ

WOP-2035V

3.5" QVGA Operator Panel with PM Designer 2.0 Software



Features

- Various LCD sizes (3.5", 5.7", 7", 8", 10.4", 12.1")
- Supports ARM9-based CPUs with 70~200MHz and 4~16MB flash memory
- Supports RTC, battery backup RAM, and Ethernet-based operator panels
- Supports runtime data downloads through Serial, Ethernet, USB
- Supports adjustable brightness controls via touch panel
- Reliable firmware for 24/7 operation
- Supports Windows XP/ Vista-based PM Designer 2.0 development tool
- Easy to switch one application to different LCD sizes in seconds
- Supports vertical and horizontal application screen rotation
- Supports over 250 PLC industrial communication protocols
- Communicates with up to four types of devices
- Panel mounting for machinery

Introduction

To satisfy the stringent standards required in the automation market, especially packaging, label slitting, and motion-based robot dispensing, Advantech offers the WOP-2000 series which are designed with ARM9-based RISC CPU with 70~200MHz and 4~16MB flash memory size for application software. The WOP-2000 series also support a variety of LCD size from 3.5" to 12.1" for different applications involving the use of PLCs, motion/thermal controllers, inverters and sensors. PM Designer 2.0 is a software development kit which helps create application solutions for labor-saving, improved efficiency of manufacturing and easy control of every machine in the factory. The WOP-2000 series is bundled with PM Designer 2.0 offering an outstanding price performance ratio for various markets such as conventional operator panels, HMI + Low mini SCADA systems, and HMI + communication gateways.

Specifications

General

- **Certifications** CE / FCC / BSMI / UL / CCC
- **Dimensions (WxHxD)** 130 x 106.2 x 45 mm (5.11" x 4.18" x 1.77")
- **Cut-out Dimensions** 118.5 x 92.5 mm (4.66" x 3.64")
- **Front Panel Thickness** 6mm
- **Operating System** HMI RTOS, PM Designer 2.0
- **Power Supply Voltage** 24V_{DC} ±10%
- **Power Consumption** 10W
- **Enclosure Housing** Plastic
- **Mounting** Panel
- **Weight (Net)** 0.27 kg (0.59 lbs)

System Hardware

- **CPU** RISC 32bits, 70MHz
- **Battery Backup Memory** 128KB
- **Flash Memory** 4MB
- **Power-On LED** Yes
- **Communication LED** No
- **Front USB Access** No

Communication Interface

- **COM1** RS-232/422/485 (DB9 Female)
- **COM2** RS-422/485 (5-Pin Plug Connector)
- **COM3** None
- **Ethernet (RJ45)** 10/100-BaseT (for N1AE model)
- **I/Os**
 - USB Client No
 - USB Host No
 - Micro-SD Slot No

LCD Display and Touchscreen

- **Display Type** QVGA TFT LCD
- **Display Size** 3.5"
- **Max. Resolution** 320 x 240
- **Max. Colors** 265 colors
- **Luminance (cd/m²)** 350
- **Viewing Angle (H/V°)** 120/120
- **Backlight Life** LED, 20,000 hrs
- **Dimming** Adjustable by touch panel
- **Touchscreen** 4 wire analog resistive

Environment

- **Operating Temperature** 0 ~ 50° C (32 ~ 122° F)
- **Storage Temperature** -20 ~ 60° C (-4 ~ 140° F)
- **Humidity** 10 ~ 95% RH @ 40° C, non-condensing
- **Ingress Protection** Front panel: NEMA4, IP65
- **Vibration Protection** Operating, random vibration 1 Grms (5 ~ 500 Hz)

Ordering Information

- **WOP-2035V-S1AE** 3.5" QVGA, 4MB, RS-232/422/485
- **WOP-2035V-N1AE** 3.5" QVGA, 4MB, RS-232/422/485, Ethernet

Dimensions

Unit: mm

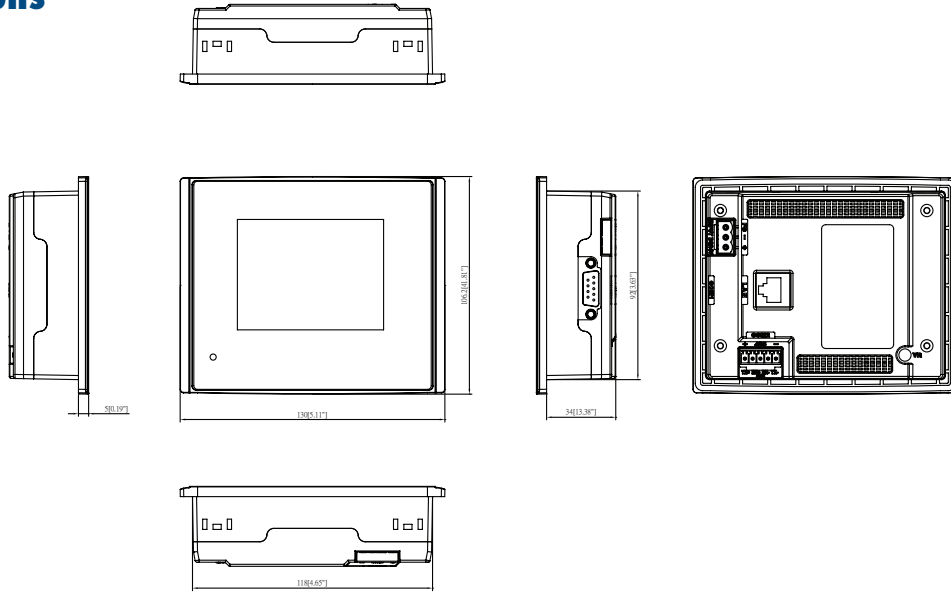

Panel Cut-out Dimensions: 118.5 x 92.5 mm (4.66" x 3.64")

Rear View

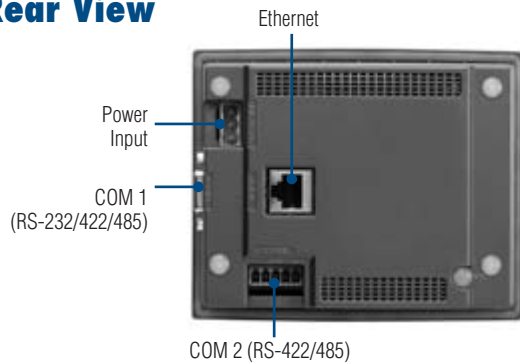

HMI Development Software Features



Communication Links

Direct Link

1-to-1 Connection

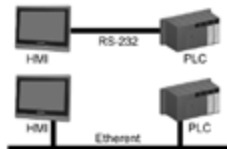

1-to-N Connection

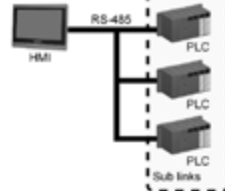

N-to-1 Data Sharing Connection

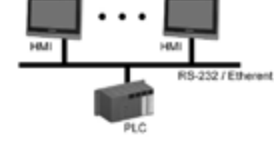

In-Direct Link

2-to-1 Connection

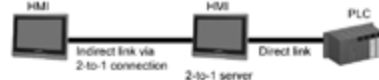

N-to-1 Connection

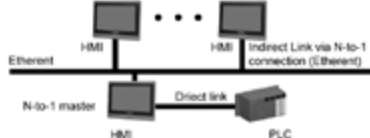

2-to-1 Transparent Connection

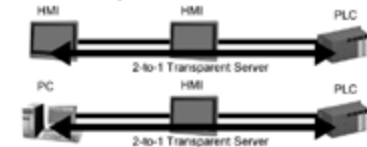

- 1 Operator Panels
- 2 Fanless Panel PCs
- 3 Panel Computers
- 4 Display Solutions
- 5 Ethernet Switches
- 6 Device Servers
- 7 Serial Comm. Cards
- 8 Video Surveillance
- 9 Pre-Configured Systems

- 10 IPC Chassis
- 11 SBCs and Backplanes
- 12 Industrial Motherboards
- 13 Embedded IPCs
- 14 Mobile Computers
- 15 IPC Peripherals
- 16 DAQ
- 17 Signal Conditioning
- 18 USB DAQ

WOP-2057V

5.7" QVGA Operator Panel with PM Designer 2.0 Software



Features

- Various LCD sizes (3.5", 5.7", 7", 8", 10.4", 12.1")
- Supports ARM9-based CPUs with 70~200MHz and 4~16M flash memory size
- Supports RTC, battery backup RAM, and Ethernet-based operator panels
- Supports Runtime data downloads through Serial, Ethernet, USB
- Supports adjustable brightness controls via touch panel
- Reliable firmware for 24/7 operation
- Supports Windows XP/ Vista-based PM Designer 2.0 development tool
- Easy to switch one application to different LCD sizes in seconds
- Supports vertical and horizontal application screen rotation
- Supports over 250 PLC industrial communication protocols
- Communicates with up to four types of devices
- Panel mounting for machinery

Introduction

To satisfy the stringent standards required in the automation market, especially packaging, label slitting, and motion-based robot dispensing, Advantech offers the WOP-2000 series which are designed with ARM9-based RISC CPU with 70~200MHz and 4~16MB flash memory size for application software. The WOP-2000 series also support a variety of LCD size from 3.5" to 12.1" for different applications involving the use of PLCs, motion/thermal controllers, inverters and sensors. PM Designer 2.0 is a software development kit which helps create application solutions for labor-saving, improved efficiency of manufacturing and easy control of every machine in the factory. The WOP-2000 series is bundled with PM Designer 2.0 offering an outstanding price performance ratio for various markets such as conventional operator panels, HMI + Low mini SCADA systems, and HMI + communication gateways.

Specifications

General

- **Certifications** CE / FCC / BSMI / UL / CCC
- **Dimensions (WxHxD)** 187 x 145.7 x 45 mm (7.36" x 5.73" x 1.77")
- **Cut-out Dimensions** 174.5 x 132.5 mm (6.87" x 5.21")
- **Front Panel Thickness** 6mm
- **Operating System** HMI RTOS, PM Designer 2.0
- **Power Supply Voltage** 24V_{DC} ±10%
- **Power Consumption** 15W
- **Enclosure Housing** Plastic
- **Mounting** Panel
- **Weight (Net)** 0.65 kg (1.42 lbs)

System Hardware

- **CPU** RISC 32bits, 70MHz
- **Battery Backup Memory** 128KB
- **Flash Memory** 4MB
- **Power-On LED** Yes
- **Communication LED** COM1 and COM2
- **Front USB Access** No

Communication Interface

- **COM1** RS-232/422/485 (DB9 Female)
- **COM2** RS-232/422/485 (DB9 Male & 5-Pin Connector)
- **COM3** None
- **Ethernet (RJ45)** 10/100-BaseT (for N1AE model)
- **I/Os**
 - USB Client No
 - USB Host No
 - Micro-SD Slot No

LCD Display and Touchscreen

- **Display Type** QVGA TFT LCD
- **Display Size** 5.7"
- **Max. Resolution** 320 x 240
- **Max. Colors** 265 colors
- **Luminance (cd/m²)** 400
- **Viewing Angle (H/V°)** 100/95
- **Backlight Life** LED, 20,000 hrs
- **Dimming** Adjustable by touch panel
- **Touchscreen** 4 wire analog resistive

Environment

- **Operating Temperature** 0 ~ 50° C (32 ~ 122° F)
- **Storage Temperature** -20 ~ 60° C (-4 ~ 140° F)
- **Humidity** 10 ~ 95% RH @ 40° C, non-condensing
- **Ingress Protection** Front panel: NEMA4, IP65
- **Vibration Protection** Operating, random vibration 1 Grms (5 ~ 500 Hz)

Ordering Information

- **WOP-2057V-S1AE** 5.7" QVGA, 4MB, RS-232/422/485
- **WOP-2057V-N1AE** 5.7" QVGA, 4MB, RS-232/422/485, Ethernet

Dimensions

Unit: mm

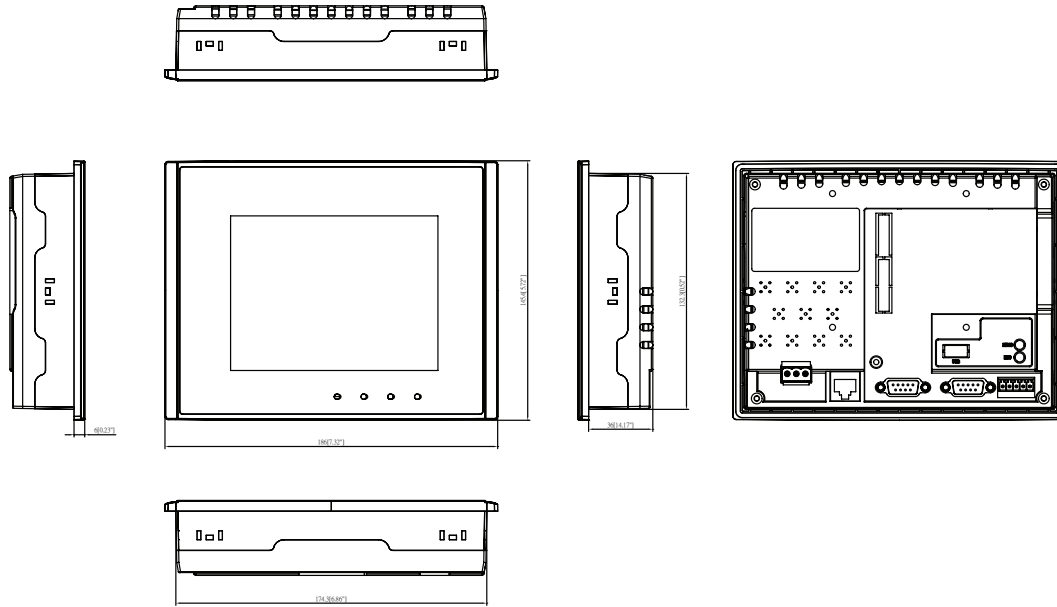

Panel Cut-out Dimensions: 174.5 x 132.5 mm (6.87" x 5.21")

Rear View

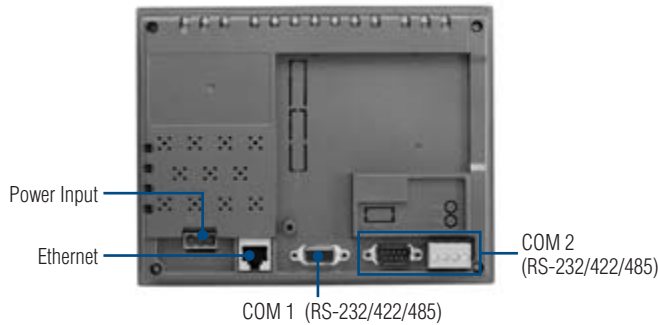

HMI Development Software Features



Communication Links

Direct Link

1-to-1 Connection

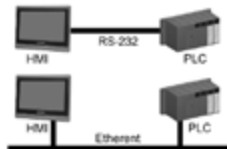

1-to-N Connection

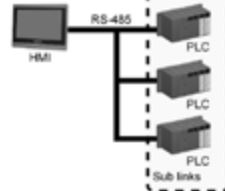

N-to-1 Data Sharing Connection

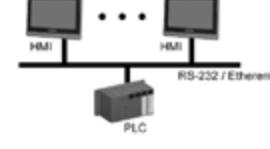

In-Direct Link

2-to-1 Connection

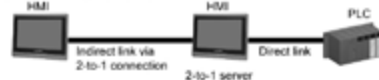

N-to-1 Connection

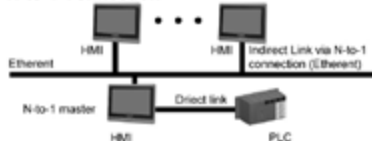

2-to-1 Transparent Connection

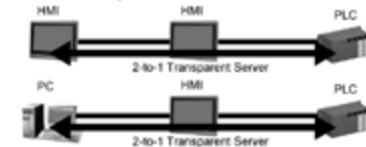

- 1 Operator Panels
- 2 Fanless Panel PCs
- 3 Panel Computers
- 4 Display Solutions
- 5 Ethernet Switches
- 6 Device Servers
- 7 Serial Comm. Cards
- 8 Video Surveillance
- 9 Pre-Configured Systems
- 10 IPC Chassis
- 11 SBCs and Backplanes
- 12 Industrial Motherboards
- 13 Embedded IPCs
- 14 Mobile Computers
- 15 IPC Peripherals
- 16 DAQ
- 17 Signal Conditioning
- 18 USB DAQ

WOP-2070V

7" WVGA Operator Panel with PM Designer 2.0 Software



Features

- Various LCD sizes (3.5", 5.7", 7", 8", 10.4", 12.1")
- Supports ARM9-based CPUs with 70~200MHz and 4~16M flash memory size
- Supports RTC, battery backup RAM, and Ethernet-based operator panels
- Supports runtime data downloads through Serial, Ethernet, USB
- Supports adjustable brightness controls via touch panel
- Reliable firmware for 24/7 operation
- Supports Windows XP/ Vista-based PM Designer 2.0 development tool
- Easy to switch one application to different LCD sizes in seconds
- Supports vertical and horizontal application screen rotation
- Supports over 250 PLC industrial communication protocols
- Communicates with up to four types of devices
- Panel mounting for machinery

Introduction

To satisfy the stringent standards required in the automation market, especially packaging, label slitting, and motion-based robot dispensing, Advantech offers the WOP-2000 series which are designed with ARM9-based RISC CPU with 70~200MHz and 4~16MB flash memory size for application software. The WOP-2000 series also support a variety of LCD size from 3.5" to 12.1" for different applications involving the use of PLCs, motion/thermal controllers, inverters and sensors. PM Designer 2.0 is a software development kit which helps create application solutions for labor-saving, improved efficiency of manufacturing and easy control of every machine in the factory. The WOP-2000 series is bundled with PM Designer 2.0 offering an outstanding price performance ratio for various markets such as conventional operator panels, HMI + Low mini SCADA systems, and HMI + communication gateways.

Specifications

General

- **Certifications** CE / FCC / BSMI / UL / CCC
- **Dimensions (WxHxD)** 188 x 143.3 x 40 mm (7.4" x 5.64" x 1.57")
- **Cut-out Dimensions** 174.5 x 132.5 mm (6.87" x 5.21")
- **Front Panel Thickness** 6mm
- **Operating System** HMI RTOS, PM Designer 2.0
- **Power Supply Voltage** 24V_{DC} ±10%
- **Power Consumption** 25W
- **Enclosure Housing** Plastic
- **Mounting** Panel
- **Weight (Net)** 1 kg (2.2 lbs)

System Hardware

- **CPU** RISC 32 bits, 200 MHz
- **Battery Backup Memory** 128KB
- **Flash Memory** 16 MB
- **Power-On LED** Yes
- **Communication LED** No
- **Front USB Access** No

Communication Interface

- **COM1** RS-232/422/485 (DB9 Female)
- **COM2** RS-232/422/485 (DB9 Male & 5-Pin Plug Connector)
- **COM3** None
- **Ethernet (RJ45)** 10/100-BaseT
- **I/Os**
 - USB Client No
 - USB Host Yes
 - Micro-SD Slot No

LCD Display and Touchscreen

- **Display Type** WVGA TFT LCD
- **Display Size** 7"
- **Max. Resolution** 800 x 480
- **Max. Colors** 65,536 colors
- **Luminance (cd/m²)** 300
- **Viewing Angle (H/V°)** 140/130
- **Backlight Life** LED, 20,000 hrs
- **Dimming** Adjustable by touch panel
- **Touchscreen** 4 wire analog resistive

Environment

- **Operating Temperature** 0 ~ 50° C (32 ~ 122° F)
- **Storage Temperature** -20 ~ 60° C (-4 ~ 140° F)
- **Humidity** 10 ~ 95% RH @ 40° C, non-condensing
- **Ingress Protection** Front panel: NEMA4, IP65
- **Vibration Protection** Operating, random vibration 1 Grms (5 ~ 500 Hz)

Ordering Information

- **WOP-2070V-N4AE** 7" WVGA, 16 MB, RS-232/422/485, Ethernet

Dimensions

Unit: mm

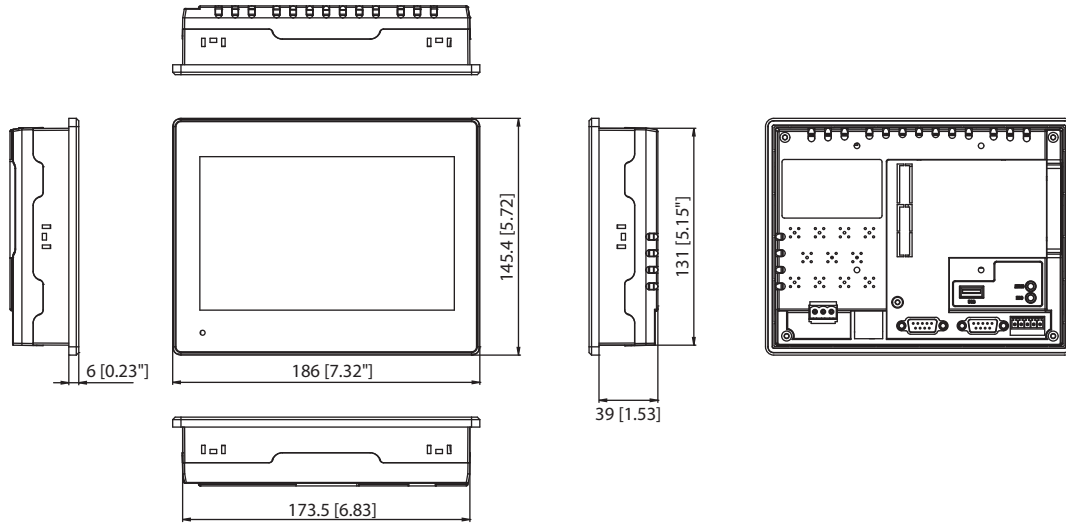

Panel Cut Out Dimensions: 174.5 x 132.5 mm

Rear View

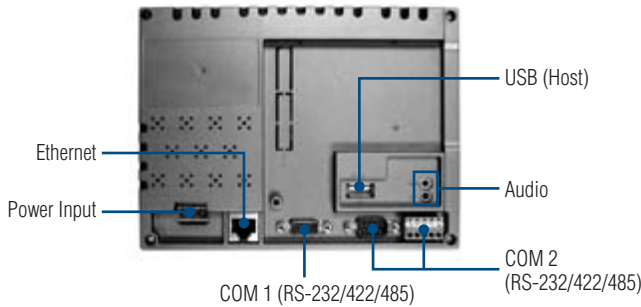

HMI Development Software Features



Communication Links

Direct Link

1-to-1 Connection

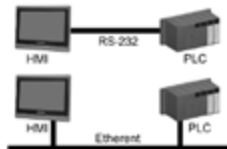

1-to-N Connection

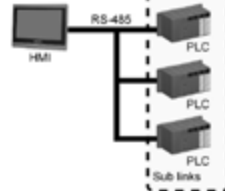

N-to-1 Data Sharing Connection

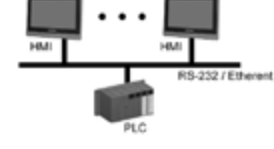

In-Direct Link

2-to-1 Connection

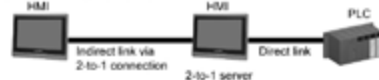

N-to-1 Connection

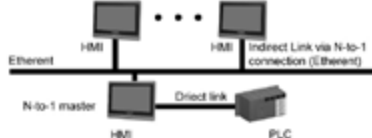

2-to-1 Transparent Connection

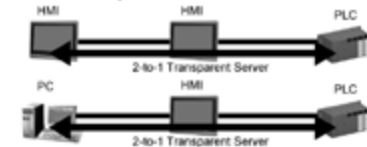

- 1 Operator Panels
- 2 Fanless Panel PCs
- 3 Panel Computers
- 4 Display Solutions
- 5 Ethernet Switches
- 6 Device Servers
- 7 Serial Comm. Cards
- 8 Video Surveillance
- 9 Pre-Configured Systems

- 10 IPC Chassis
- 11 SBCs and Backplanes
- 12 Industrial Motherboards
- 13 Embedded IPCs
- 14 Mobile Computers
- 15 IPC Peripherals
- 16 DAQ
- 17 Signal Conditioning
- 18 USB DAQ

WOP-2080V

8" SVGA Operator Panel with PM Designer 2.0 Software



Features

- Various LCD sizes (3.5", 5.7", 7", 8", 10.4", 12.1")
- Supports ARM9-based CPUs with 70~200MHz and 4~16M flash memory size
- Supports RTC, battery backup RAM, and Ethernet-based operator panels
- Supports Runtime data downloads through Serial, Ethernet, USB
- Supports adjustable brightness controls via touch panel
- Reliable firmware for 24/7 operation
- Supports Windows XP/ Vista-based PM Designer 2.0 development tool
- Easy to switch one application to different LCD sizes in seconds
- Supports vertical and horizontal application screen rotation
- Supports over 250 PLC industrial communication protocols
- Communicates with up to four types of devices
- Panel mounting for machinery

Introduction

To satisfy the stringent standards required in the automation market, especially packaging, label slitting, and motion-based robot dispensing, Advantech offers the WOP-2000 series which are designed with ARM9-based RISC CPU with 70~200MHz and 4~16MB flash memory size for application software. The WOP-2000 series also support a variety of LCD size from 3.5" to 12.1" for different applications involving the use of PLCs, motion/thermal controllers, inverters and sensors. PM Designer 2.0 is a software development kit which helps create application solutions for labor-saving, improved efficiency of manufacturing and easy control of every machine in the factory. The WOP-2000 series is bundled with PM Designer 2.0 offering an outstanding price performance ratio for various markets such as conventional operator panels, HMI + Low mini SCADA systems, and HMI + communication gateways.

Specifications

General

- **Certifications** CE / FCC / BSMI / UL / CCC
- **Dimensions (WxHxD)** 232.5 x 175.8 x 42.9 mm (9.15" x 6.92" x 1.69")
- **Cut-out Dimensions** 221.5 x 164 mm (8.72" x 6.45")
- **Front Panel Thickness** 6 mm
- **Operating System** HMI RTOS, PM Designer 2.0
- **Power Supply Voltage** 24V_{DC} ±10%
- **Power Consumption** 25W
- **Enclosure Housing** Plastic
- **Mounting** Panel
- **Weight (Net)** 1 kg (2.2 lbs)

System Hardware

- **CPU** RISC 32bits, 200MHz
- **Battery Backup Memory** 128KB
- **Flash Memory** 16MB
- **Power-On LED** Yes
- **Communication LED** COM1, COM2 and COM3
- **Front USB Access** No

Communication Interface

- **COM1** RS-232/422/485 (DB9 Female)
- **COM2** RS-232/422/485 (DB9 Male & 5-Pin Plug Connector)
- **COM3** RS-232 (6-Pin Plug Connector)
- **Ethernet (RJ45)** 10/100-BaseT
- **I/Os**
 - USB Client Yes
 - USB Host No
 - Micro-SD Slot No

LCD Display and Touchscreen

- **Display Type** SVGA TFT LCD
- **Display Size** 8"
- **Max. Resolution** 800 x 600
- **Max. Colors** 65,536 colors
- **Luminance (cd/m²)** 350
- **Viewing Angle (H/V°)** 140/130
- **Backlight Life** LED, 50,000 hrs
- **Dimming** Adjustable by touch panel
- **Touchscreen** 4 wire analog resistive

Environment

- **Operating Temperature** 0 ~ 50° C (32 ~ 122° F)
- **Storage Temperature** -20 ~ 60° C (-4 ~ 140° F)
- **Humidity** 10 ~ 95% RH @ 40° C, non-condensing
- **Ingress Protection** Front panel: NEMA4, IP65
- **Vibration Protection** Operating, random vibration 1 Grms (5 ~ 500 Hz)

Ordering Information

- **WOP-2080V-N4AE** 8" SVGA, 16MB, RS-232/422/485, Ethernet

Dimensions

Unit: mm

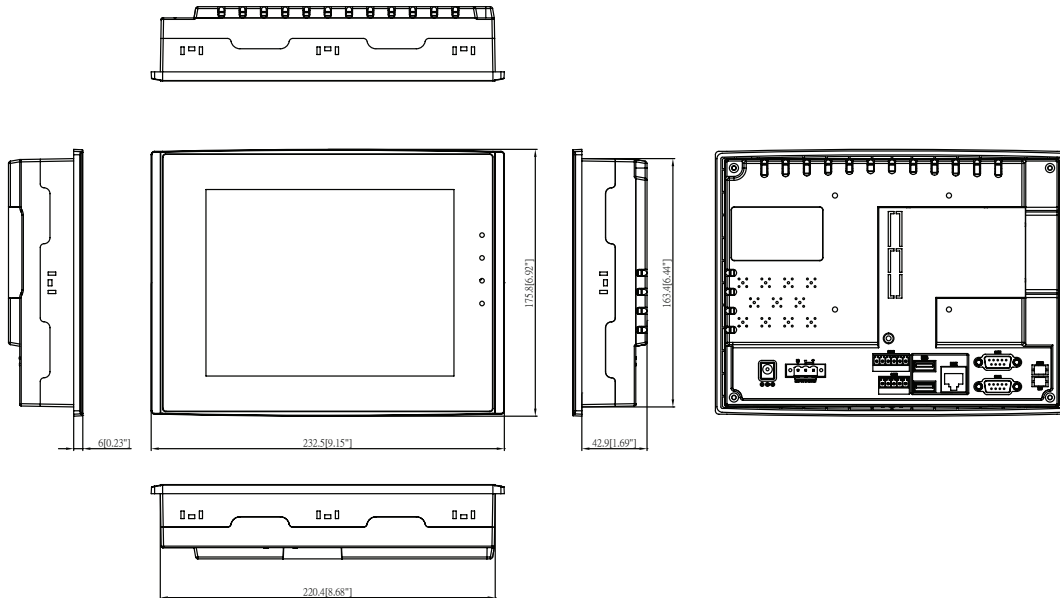

Panel Cut-out Dimensions: 221.5 x 164 mm (8.72" x 6.45")

Rear View

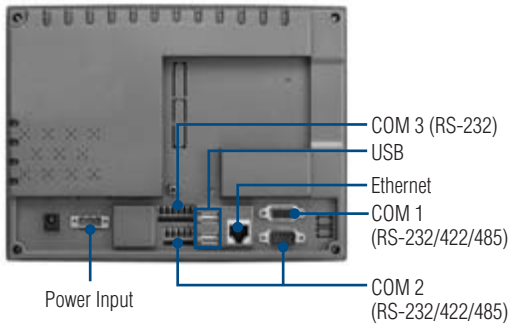

HMI Development Software Features



Communication Links

Direct Link

1-to-1 Connection

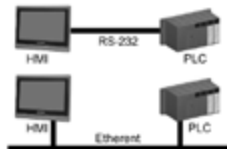

1-to-N Connection

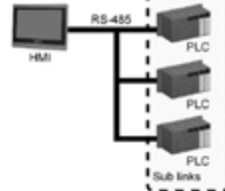

N-to-1 Data Sharing Connection

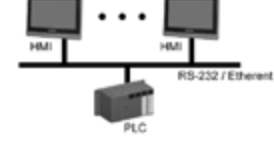

In-Direct Link

2-to-1 Connection

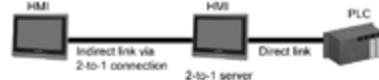

N-to-1 Connection

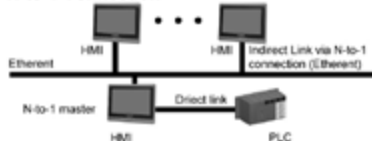

2-to-1 Transparent Connection

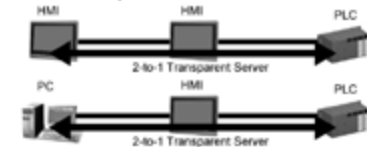

- 1 Operator Panels
- 2 Fanless Panel PCs
- 3 Panel Computers
- 4 Display Solutions
- 5 Ethernet Switches
- 6 Device Servers
- 7 Serial Comm. Cards
- 8 Video Surveillance
- 9 Pre-Configured Systems

- 10 IPC Chassis
- 11 SBCs and Backplanes
- 12 Industrial Motherboards
- 13 Embedded IPCs
- 14 Mobile Computers
- 15 IPC Peripherals
- 16 DAQ
- 17 Signal Conditioning
- 18 USB DAQ

WOP-2104V

10.4" SVGA Operator Panel with PM Designer 2.0 Software



Features

- Various LCD sizes (3.5", 5.7", 7", 8", 10.4", 12.1")
- Supports ARM9-based CPUs with 70~200MHz and 4~16M flash memory size
- Supports RTC, battery backup RAM, and Ethernet-based operator panels
- Supports Runtime data downloads through Serial, Ethernet, USB
- Supports adjustable brightness controls via touch panel
- Reliable firmware for 24/7 operation
- Supports Windows XP/ Vista-based PM Designer 2.0 development tool
- Easy to switch one application to different LCD sizes in seconds
- Supports vertical and horizontal application screen rotation
- Supports over 250 PLC industrial communication protocols
- Communicates with up to four types of devices
- Panel mounting for machinery

Introduction

To satisfy the stringent standards required in the automation market, especially packaging, label slitting, and motion-based robot dispensing, Advantech offers the WOP-2000 series which are designed with ARM9-based RISC CPU with 70~200MHz and 4~16MB flash memory size for application software. The WOP-2000 series also support a variety of LCD size from 3.5" to 12.1" for different applications involving the use of PLCs, motion/thermal controllers, inverters and sensors. PM Designer 2.0 is a software development kit which helps create application solutions for labor-saving, improved efficiency of manufacturing and easy control of every machine in the factory. The WOP-2000 series is bundled with PM Designer 2.0 offering an outstanding price performance ratio for various markets such as conventional operator panels, HMI + Low mini SCADA systems, and HMI + communication gateways.

Specifications

General

- **Certifications** CE / FCC / BSMI / UL / CCC
- **Dimensions (WxHxD)** 297 x 224 x 52 mm (11.6" x 8.8" x 2.04")
- **Cut-out Dimensions** 285.5 x 210.5 mm (11.24" x 8.28")
- **Front Panel Thickness** 6mm
- **Operating System** HMI RTOS, PM Designer 2.0
- **Power Supply Voltage** 24V_{DC} ±10%
- **Power Consumption** 25W
- **Enclosure Housing** Plastic
- **Mounting** Panel
- **Weight (Net)** 1.55 kg (3.41 lbs)

System Hardware

- **CPU** RISC 32bits, 200MHz
- **Battery Backup Memory** 128KB
- **Flash Memory** 16MB
- **Power-On LED** Yes
- **Communication LED** COM1, COM2 and COM3
- **Front USB Access** Yes

Communication Interface

- **COM1** RS-232/422/485 (DB9 Female)
- **COM2** RS-232/422/485 (DB9 Male & 5-Pin Plug Connector)
- **COM3** RS-232 (6-Pin Plug Connector)
- **Ethernet (RJ45)** 10/100-BaseT
- **I/Os**
 - USB Client Yes
 - USB Host No
 - Micro-SD Slot No

LCD Display and Touchscreen

- **Display Type** SVGA TFT LCD
- **Display Size** 10.4"
- **Max. Resolution** 800 x 600
- **Max. Colors** 65,536 colors
- **Luminance (cd/m²)** 300
- **Viewing Angle (H/V°)** 140/120
- **Backlight Life** LED, 30,000
- **Dimming** Adjustable by touch panel
- **Touchscreen** 4 wire analog resistive

Environment

- **Operating Temperature** 0 ~ 50° C (32 ~ 122° F)
- **Storage Temperature** -20 ~ 60° C (-4 ~ 140° F)
- **Humidity** 10 ~ 95% RH @ 40° C, non-condensing
- **Ingress Protection** Front panel: NEMA4, IP65
- **Vibration Protection** Operating, random vibration 1 Grms (5 ~ 500 Hz)

Ordering Information

- **WOP-2104V-N4AE** 10.4" SVGA, 16MB, RS-232/422/485, Ethernet

Dimensions

Unit: mm

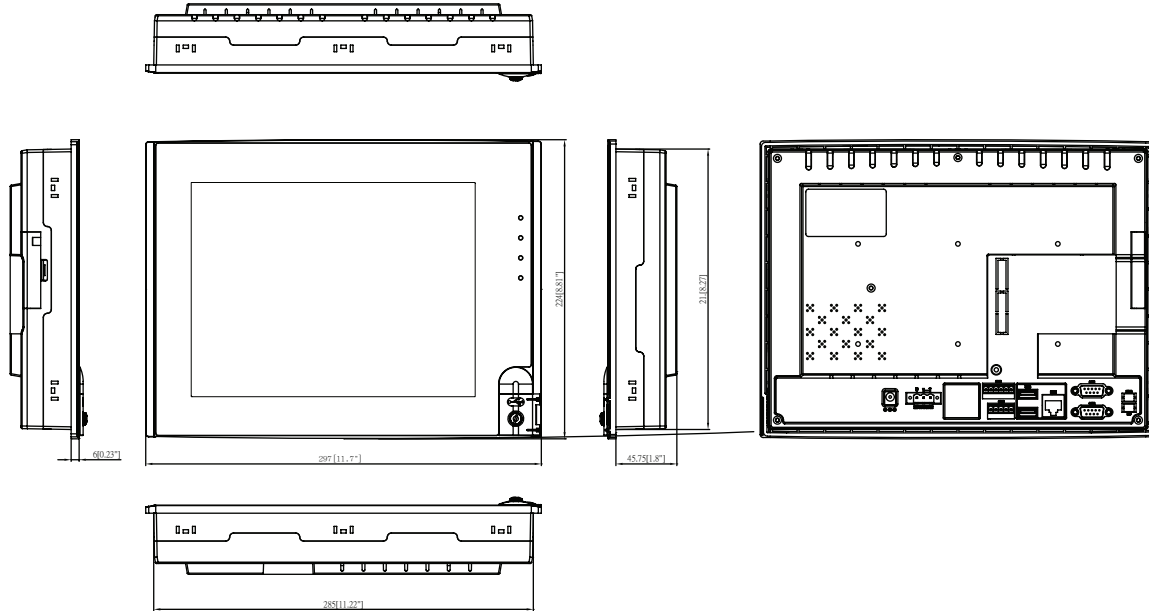

Panel Cut-out Dimensions: 285.5 x 210.5 mm (11.24" x 8.28")

Front USB Access



Rear View

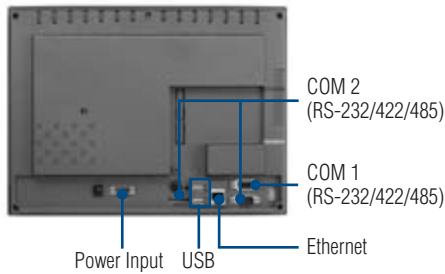

HMI Development Software Features



Communication Links

Direct Link

1-to-1 Connection

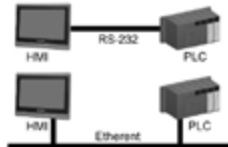

1-to-N Connection

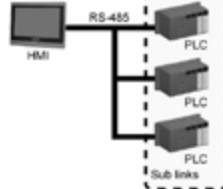

N-to-1 Data Sharing Connection

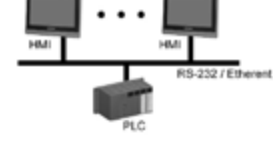

In-Direct Link

2-to-1 Connection

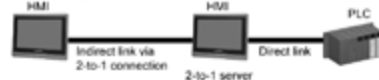

N-to-1 Connection

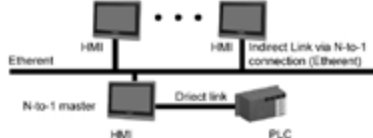

2-to-1 Transparent Connection

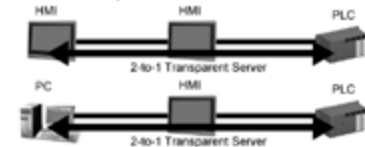

- 1 Operator Panels
- 2 Fanless Panel PCs
- 3 Panel Computers
- 4 Display Solutions
- 5 Ethernet Switches
- 6 Device Servers
- 7 Serial Comm. Cards
- 8 Video Surveillance
- 9 Pre-Configured Systems

- 10 IPC Chassis
- 11 SBCs and Backplanes
- 12 Industrial Motherboards
- 13 Embedded IPCs
- 14 Mobile Computers
- 15 IPC Peripherals
- 16 DAQ
- 17 Signal Conditioning
- 18 USB DAQ

WOP-2121V

12.1" SVGA Operator Panel with PM Designer 2.0 Software



Features

- Various LCD sizes (3.5", 5.7", 7", 8", 10.4", 12.1")
- Supports ARM9-based CPUs with 70~200MHz and 4~16M flash memory size
- Supports RTC, battery backup RAM, and Ethernet-based operator panels
- Supports runtime data downloads through Serial, Ethernet, USB
- Supports adjustable brightness controls via touch panel
- Reliable firmware for 24/7 operation
- Supports Windows XP/Vista-based PM Designer 2.0 development tool
- Easy to switch one application to different LCD sizes in seconds
- Supports vertical and horizontal application screen rotation
- Supports over 250 PLC industrial communication protocols
- Communicates with up to four types of devices
- Panel mounting for machinery

Introduction

To satisfy the stringent standards required in the automation market, especially packaging, label slitting, and motion-based robot dispensing, Advantech offers the WOP-2000 series which are designed with ARM9-based RISC CPU with 70~200MHz and 4~16MB flash memory size for application software. The WOP-2000 series also support a variety of LCD size from 3.5" to 12.1" for different applications involving the use of PLCs, motion/thermal controllers, inverters and sensors. PM Designer 2.0 is a software development kit which helps create application solutions for labor-saving, improved efficiency of manufacturing and easy control of every machine in the factory. The WOP-2000 series is bundled with PM Designer 2.0 offering an outstanding price performance ratio for various markets such as conventional operator panels, HMI + Low mini SCADA systems, and HMI + communication gateways.

Specifications

General

- **Certifications** CE / FCC / BSMI / UL / CCC
- **Dimensions (WxHxD)** 315 x 241 x 54.5 mm (12.4" x 9.48" x 2.14")
- **Cut-out Dimensions** 301.5 x 228 mm (11.87" x 8.97")
- **Front Panel Thickness** 6mm
- **Operating System** HMI RTOS, PM Designer 2.0
- **Power Supply Voltage** 24V_{DC} ±10%
- **Power Consumption** 25W
- **Enclosure Housing** Plastic
- **Mounting** Panel
- **Weight (Net)** 1.55 kg (3.41 lbs)

System Hardware

- **CPU** RISC 32bits, 200MHz
- **Battery Backup Memory** 128KB
- **Flash Memory** 16MB
- **Power-On LED** Yes
- **Communication LED** COM1, COM2 and COM3
- **Front USB Access** No

Communication Interface

- **COM1** RS-232/422/485 (DB9 Female)
- **COM2** RS-232/422/485 (DB9 Male & 5-Pin Plug Connector)
- **COM3** RS-232 (6-Pin Plug Connector)
- **Ethernet (RJ45)** 10/100-BaseT
- **I/Os**
 - USB Client Yes
 - USB Host No
 - Micro-SD Slot No

LCD Display and Touchscreen

- **Display Type** SVGA TFT LCD
- **Display Size** 12.1"
- **Max. Resolution** 800 x 600
- **Max. Colors** 65,536 colors
- **Luminance (cd/m²)** 350
- **Viewing Angle (H/V°)** 130/110
- **Backlight Life** CCFL, 30,000
- **Dimming** Adjustable by touch panel
- **Touchscreen** 8 wire analog resistive

Environment

- **Operating Temperature** 0 ~ 50° C (32 ~ 122° F)
- **Storage Temperature** -20 ~ 60° C (-4 ~ 140° F)
- **Humidity** 10 ~ 95% RH @ 40° C, non-condensing
- **Ingress Protection** Front panel: NEMA4, IP65
- **Vibration Protection** Operating, random vibration 1 Grms (5 ~ 500 Hz)

Ordering Information

- **WOP-2121V-N4AE** 12.1" SVGA, 16MB, RS-232/422/485, Ethernet

Dimensions

Unit: mm

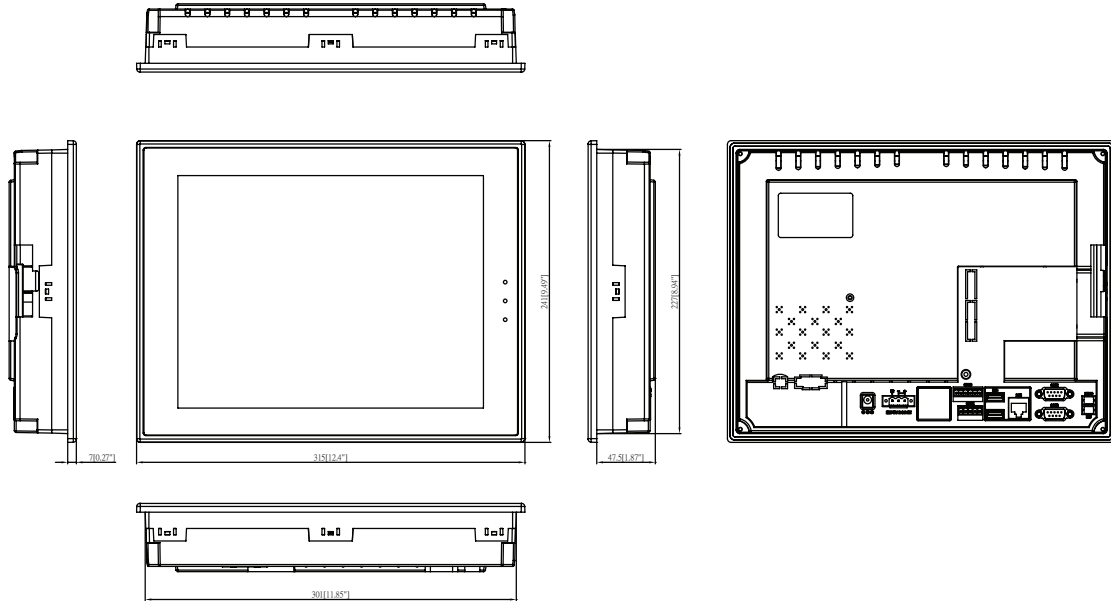

Panel Cut-out Dimensions: 301.5 x 228 mm (11.87" x 8.97")

Rear View

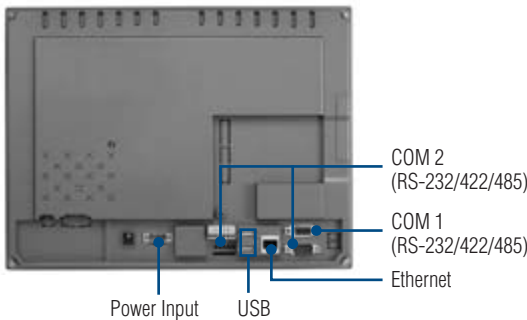

HMI Development Software Features



Communication Links

Direct Link

1-to-1 Connection

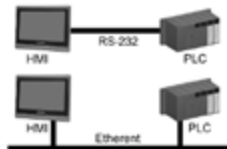

1-to-N Connection

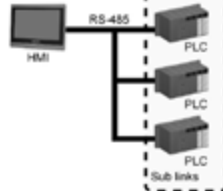

N-to-1 Data Sharing Connection

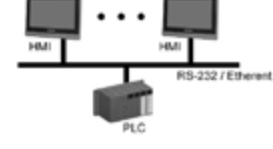

In-Direct Link

2-to-1 Connection

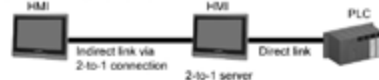

N-to-1 Connection

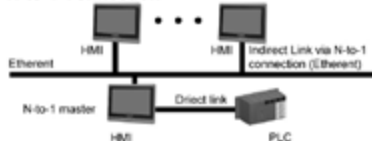

2-to-1 Transparent Connection

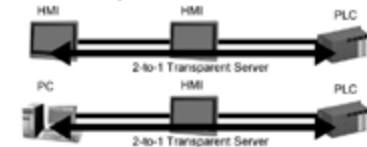

- 1 Operator Panels
- 2 Fanless Panel PCs
- 3 Panel Computers
- 4 Display Solutions
- 5 Ethernet Switches
- 6 Device Servers
- 7 Serial Comm. Cards
- 8 Video Surveillance
- 9 Pre-Configured Systems

- 10 IPC Chassis
- 11 SBCs and Backplanes
- 12 Industrial Motherboards
- 13 Embedded IPCs
- 14 Mobile Computers
- 15 IPC Peripherals
- 16 DAQ
- 17 Signal Conditioning
- 18 USB DAQ

Supported PLC Controllers

Communication Port (COM)

Brand	Model	Driver Name
A&D Company Ltd.	AD-4401 Weighing Indicator	CAD401
ABIDO Automation Co., Ltd.	ACR420 984 Device/Slave (RTU)	C2C032
ADLEE POWERTRONIC CO., LTD.	MS/AP/AS Series Inverter (RTU)	CAPINV
	BL/D305 Series (RTU)	CAPIPM
AIGO Technologies Corporation	SE500 Series (Modbus RTU)	C87001
	Micrologix 1000/1500	C10001
Allen Bradley	SLC 5/03, 5/04	C10002
	DH-485 (COM)	C10003
ARICO Technology	FC Type(Modbus)	Carfc01
Automation Technology Co., Ltd.	BLDC NLV/KLV Series	CAK200
Bosch Rexroth Group	Convo CVF-MN3 (RS485 Model)	C49001
CAPAC	TC	CCAP01
CHINO Corporation	DB1000 Digital Indicating Controller (ASCII)	CCDB1k
CMZ Sistemi Elettronici	NFO Controllers	CGMZ051
	FCT Controllers	CGMZ151
	SD Drivers	CGMZ251
	SDS Drivers	CGMZ351
	MDM Drivers	CGMZ451
CTB Technologies Corporation	IMS Servo Controller	CAA001
Danfoss Group	VLT 2800 Series (FC Protocol)	CDAVLT
Delta Corporation	DVP-ES/SS/EP/EH	C16001
	DVP-ES/SS/EP/EH (No block read)	C16001
	VFD-M Inverter (ASCII)	C16011
	VFD-B Inverter (ASCII)	C16021
	DTC1000/2000 Temperature (ASCII)	C16031
	ASDA-A Servo Controller (ASCII)	C16041
	ASDA-B Servo Controller (ASCII)	C16051
Dirise Electric Technology Co.,Ltd.	DRS2000 Series Inverter	C15101
	DRS2800 M Series Inverter	CFDSR01
Emerson Network Power	EC Series (RTU)	C81001
	EV1000 Series Variable Speed Driver	C81011
Epson Corporate	Epson LQ Matrix Printer	CEPSON0
Eura Drives Electric Corp.	Eura EF1S/1N	C2B001
	Eura EF2N	C2B041
	Eura Inverter (Modbus RTU)	C2C051
	Eura Inverter (Modbus ASCII)	C2C093
Fatek Automation Corp.	FATEK FBs/FBe	C1A001
Festo Corporation	FPC/FEC Series	C1C001
Fuji Electric Corporation	NB Series	C1D001
	PXR Series Temperature (RTU)	C1D011
	FRENIC-VP (RTU)	C1D021
	FRENIC5000G11/P11 (Fuji)	C1D031
FKV Automation Co., Ltd.	F Series Inverter	CFDSR01
GE Corporation	90 Series SNP	C1E001
	90 Series CCM	C1E011
Gigarise Technology Co., Ltd.	SE5000	C87002
	GA400 Temperature (RTU)	C90012
GOFAST Corporation	NC Series	C42001
Hanbell Precise Machinery Co., Ltd.	Air Screw Compressor	CHANASC
Hitachi Industrial Equipment Systems Co., Ltd	SJ200 Inverter	C1F001
	H/EH Series	C1F020
	EHV Series (Procedure 1)	C1F021
	H-252C	C1F022
	AD Series Servo Drives	CHA04LS
Hitech	Computer as Slave (COM)	C02001
	Computer as Master (COM)	C02011
	Computer as Slave V2 (COM)	C02021
	Computer as Master V2 (COM)	C02031
HOLIP ELECTRONIC TECHNOLOGY CO., LTD	HLP-C+/CP	CHLP01
Honeywell	BACnet/MSTP	cbacmst
	BACnet	cbacnet
Hunjoen Electronic Co., Ltd.	H_Tech PID CONTROLLER	Chtech1
HUST Automation Inc.	CNC Controller	CHCNC01
Idec Corporation	FC Series	C22001
Inovance Control Technology Co., Ltd.	H2u (CPU Port)	C2B041
	MD Series Inverter (RTU)	C2C051
Integrated Flow Systems	iPurge Source Controller	CIF001
JETTER	NANO Series	C24001

Brand	Model	Driver Name
JETTER	JetControl 24x Series	C24011
Keyence Corp.	KV Series	C25001
	KV-1000	C25011
	KV-L20V	C25021
Klockner Moeller Corporation	PS4-201-MM1	C26001
	SUCONET K	CSUK01
Koyo Electric Corp.	K Sequence Series	C27001
	Direct Logic Series	C27011
	Direct 06 Series (K Sequence)	C27021
	Direct 06 Series (DirectNET)	C27031
Lenze Drive Systems GmbH	93xx Servo Controllers (LECOM A/B)	CLZ001
	Master-K Series CNet	C28001
LG Industrial Systems	K120S CPU Port	C28011
	Master-K Loader	C28011
	GLOFA GM Series CNet	C28021
	XBM-DR16S	C28031
	GLOFA GM Loader	C28041
	XEC/XGI CNet	C28051
LG System	LGA Series(as Slave)	CLGLGA
	LGA Series (as Master)	CLGLGB
Liyen Electric Industrial Ltd.	EX Series (CPU Port)	C2B141
Lust Antriebstechnik GmbH	LustBus ServoC/CDE Series	Clust1
	LustBus CDD Series	Clust1
Matsushita Electric Works	FP Series Computer Link	C29001
	VFOC Series Inverter	C29011
Maxtech	MC2 PID Controller	C85001
Maxthermo	MC 5738 (RTU)	C86001
Micro Trend Corporation	UTC Servo Controller	C91001
Mirle Automation Corporation	nDX Controller	C2A001
	Melsec-FX (CPU Port)	C2B001
Mitsubishi Electric Corp.	Melsec-Q/QnA (Link Port)	C2B011
	Melsec-Q00/01 (CPU Port)	C2B012
	Melsec-Q02H (CPU Port)	C2B021
	Melsec-Q00J (CPU Port)	C2B031
	Melsec-FX2n (CPU Port)	C2B041
	Melsec-FX3U (CPU Port)	C2B051
	Melsec-FX3U (Link Port)	C2B052
	Melsec-AnN/AnS (Link Port)	C2B061
	FX2n-10GM/20GM	C2B071
	Melsec-A1S/A2S (CPU Port)	C2B081
	FR-E500 Series (485)	C2B091
	Melsec-A3N/A1SH (CPU Port)	C2B0A1
	Melsec-AnA/AnU (Link Port)	C2B151
	Servo Amplifier MR-J2S-A	C2B161
	Melsec-A2A/A2AS (CPU Port)	C2B171
	Melsec-Q06H (CPU Port)	C2B181
	Mitutoyo Corporation	EV Linear Gage Counter (ASCII)
Modicon 984 Master (RTU)		C2C021
Modicon Corp.	Modicon 984 Master (RTU; Little Memory)	C2C022
	Modicon 984 Device/Slave (RTU)	C2C031
	Modbus Master (ASCII)	C2C061
	Modbus Master (ASCII; Little Memory)	C2C062
	Modbus Device/Slave (ASCII)	C2C071
	Modicon Device/Slave (RTU, Quantum)	C2C081
	TSX Premium (Uni-Telway)	C2C0A1
	TSX Quantum (Uni-Telway)	C2C0B1
	Twido (Modbus RTU)	C2C0C1
	Modbus Master (RTU; Non-volatile slave data)	C2C121
Modbus Master (ASCII; Non-volatile slave data)	C2C161	
MTC	MTC96 Controller (Modbus ASCII)	C93001
Muscle Corporation Inc.	Cool Muscle CM1-17L30	CCM117L
	PSTC (Temperature Controller)	C2C051
Newtop Co., Ltd.	PSBD (Brushless Driver)	C2C051
	PSSD (Stepping Driver)	C2C051
	PSMC (Motion Controller)	C2C051
	PSNC (Embedded NC)	C2C051

Communication Ports (COM)

Brand	Model	Driver Name
Omron Corporation	Sysmac C Series Host Link	C2D001
	Sysmac CV Series Host Link	C2D011
	Sysmac CS/CJ Series Host Link	C2D021
	Sysmac CS/CJ Series (FINS)	C2D021
	E5CN Temperature (CompoWay/F)	C2D041
	E5CN Temperature (Modbus RTU)	C2D051
	EJ1 Temperature (CompoWay/F)	C2D061
	KM100 (CompoWay/F)	C2D071
	Sysmac CP Series (FINS)	C2D021
PanelMaster	Null PLC	C00000
	General Device (COM)	C01051
	Profibus-DP Slave EP0920	C01081
	Data Sharer (RS485)	C01S01
	Modbus Master (RTU)	C2C041
	Modbus Master (RTU; Little Memory)	C2C042
	Modbus Master (RTU; Non-volatile slave data)	C2C121
	Modbus Device/Slave (RTU)	C2C051
	Modbus Device/Slave (Word order in big-endian)	C2C052
	Modbus Device/Slave (RTU; No block read)	C2C051
	Modbus Device/Slave (ASCII)	C2C071
	Modbus Device/Slave (ASCII; No block read)	C2C093
	Barcode Scanner	cbcode
	Epson Matrix Printer	CEPSON0
	N-to-1 Master (COM)	C01001
	2-to-1 Server (COM)	C01061
	2-to-1 Transparent Server (COM)	C01062
	2-to-1 Client (COM)	C01071
	Multi-drop Client (COM)	C01011
	Pan-Globe Corp.	E9 Temperature Series
E904 Temperature (RTU)		C90011
HT Series Temperature Controller		C90021
RICH Electric Co., LTD.	EI-500 Series (RTU)	CEI500
	EI-9001 Series (RTU)	CEI9001
RKC Instrument Inc.	MA900/CB900 Series (RTU)	C82001
	CD/CH Series (ASCII)	C82002
Saia Burgess	PCD Series (S-Bus PGU)	C31001
	PCD Series (S-Bus, Data Mode)	C31003
Samwon Technology	NOVA Series (RTU)	C88001
Schneider Electric	Lexium 23 Servo Controller (ASCII)	C16041
Sharp Corporation	JW10/20 Series	CSJW10
Shenzhen Step Servo Ltd.	Kinco Servo Controller	C50001
Shihlin Electric&Engineering Corp.	SH Inverter	CSSH01
SHIMAX CO., LTD.	MAC3 Series (RTU)	CSH101
Shinko Technos Co., Ltd.	CPT-20A MODBUS DEVICE/SLAVE (ASCII)	CSCCT1
	JCS-33A-R/M (Shinko Protocol)	CSJCS01
	JCS-33A-R/M (Modbus ASCII)	CSJCS11
Siemens AG	Simatic S7-200 (PPI; 1-to-1)	C39001
	Simatic S7-200 (PPI; Network)	C39011
	Simatic S7-300 (MPI Port)	C39021
	Simatic S7-300 (PC Adaptor)	C39031
	Simatic S5 3964R	C39041
	Simatic S5	C39051
Taian Automation Co.,Ltd.	TP03 Series (Modbus RTU)	C51011
	TP02 Series	C51021
Taiwan Instrument & Control Co., Ltd.	TAIE FY100/900 Series (RTU)	CFY001
	TAIE FY100/900 Series (TAIE)	CFY002
	FY series DIGITAL PID CONTROLLER	CTAIEFY
Teco Electric & Machinery Co.,Ltd.	TSDA Series AC Servo	C51001
	TP03 Series (Modbus RTU)	C51011
	TP02 Series	C51021
	TSTA Series AC Servo	C51031
TESHOW ELECTRONIC.	MY90V/MY40V Series (RTU)	CMY901
Texas Instruments Incorporated	TI505	CTI505
Thinget Electronic Co., Ltd.	XC Series Controller (RTU)	C89001
Tieon Electronics Co., Ltd.	IPC-03 Series (RTU)	C83001

Brand	Model	Driver Name
TOHO Electronics Inc.	TTX-700 (Modbus RTU)	C3D001
	TTM-000 Series (TOHO Protocol)	C3D002
	TTM-200 Series (TOHO Protocol)	C3D003
TOKY ELECTRIC	DW8-CD18B	CTDW80
Toshiba Schneider Inverter Corporation	TOSVERT VF Series (Modbus RTU)	C84001
Unitronics	Vision 120 Series (Modbus RTU)	C4A001
Vertex Technology Co., Ltd	VT26/30 Series Controllers (RTU)	CVVT26
Vigor Corporation	M/VB Series	C42001
Wanfeng Electric	WF Series	C42001
YAMAHA MOTOR CO., LTD.	Single-axis Robot Controller ERCD	CYAERCD
Yamatake Corporation	SDC35/36 Temperature (RTU)	C44001
	SDC35/36 Temperature (ASCII)	C44011
	MA500 FA Controller (ECL Host)	C44021
	DMC10 Controller (RTU)	C44031
	DMC10 Controller (ASCII)	C44041
	MX30	CYAMX30
Yaskawa Corporation	MX50	CYAMX50
	Σ-II SGM/H Series AC Servo	C45001
	MP Series Controller (Memobus)	C45011
	V7 inverter (Memobus)	C45021
YE-LI ELECTRIC & MACHINERY Co., Ltd.	NS600 Servo Controller	C45031
	YPV Servo Controller	cyeli1
	YJD Servo Controller	cyeli2
Yokogawa Electric Corporation	FA-M3 Series (CPU Port)	C46001
Yudian Automation Technology Ltd.	AI-7048 (AiBus)	C47001
	AI518/708/808/518P/708P/808P Controller (Albus)	C47011
Zhuhai Motion Control Motor Co., Ltd.	BP Series PSDA driver (RTU)	C2CBP1

1

Operator Panels

2

Fanless Panel PCs

3

Panel Computers

4

Display Solutions

5

Ethernet Switches

6

Device Servers

7

Serial Comm. Cards

8

Video Surveillance

9

Pre-Configured Systems

10

IPC Chassis

11

SBCs and Backplanes

12

Industrial Motherboards

13

Embedded IPCs

14

Mobile Computers

15

IPC Peripherals

16

DAQ

17

Signal Conditioning

18

USB DAQ

Supported PLC Controllers

Communication Port (Ethernet)

Brand	Model	Driver Name
Allen Bradley	MicroLogix 1000/1500 via 1761-NET-ENI	C10E01
CMZ Sistemi Elettronici	FCT Controllers (TCP/IP)	C2C011
	FCT Controllers (TCP/IP; Type 2)	C2C111
Fatek Automation Corp.	Fatek FBS/FBe (TCP)	C1A011
Hitachi Industrial Equipment Systems Co., Ltd	EH/EHV Series (Ethernet; TCP)	C1F006
	EH/EHV Series (Ethernet; UDP)	C1F007
Honeywell	BACnet/IP	cbacip
JETTER	JetControl 24x Series (Ethernet)	C24012
Lenze Drive Systems GmbH	E94AYCEN GCI(TCP/IP) Protocol	CLZ003
Mitsubishi Electric Corp.	Q Ethernet	C2BE11
Modicon Corp.	ModBus Master (TCP/IP)	C2C001
	ModBus Device/Slave (TCP/IP)	C2C011
	ModBus Master (TCP/IP; Type 2)	C2C101
	ModBus Device/Slave (TCP/IP; Type 2)	C2C111
Omron Corporation	Sysmac CS/CJ Series FINS/TCP	C2DE01
PanelMaster	Data Sharer (UDP)	C01E01
	Ping	C0Ping
	Modbus Device/Slave (TCP/IP)	C2C011
	N-to-1 Master (Ethernet)	C01021
	N-to-1 Slave (Ethernet)	C01031
	N-to-1 Client (Ethernet)	C01091
Saia Burgess	PCD Series (Ether-S-Bus)	C31007
Siemens AG	Simatic S7-300 Ethernet Module (CP343)	C39E01
Yaskawa Corporation	ModBus Device/Slave (TCP/IP)	C2C011
	Extended MEMOBUS	C45013

Note:

* The listing brand names are in alphabetical order.

* Driver Programs may be updated at any time, please contact with your Advantech representative at any time to confirm latest information.

Key Features:

- High-performance discrete drive to support high data acquisition.
- The Communication speed of Simatic S7-300 (MPI port) can reach 187.5 kbps without adapter.