

VCODEC-H264

Single Channel H264 Codec



The VCODEC-H264 is a single channel H264 Codec on a single PC/104plus form factor. The VCODEC-H264 provides a powerful and flexible solution for capturing and compressing an analogue video input to the H264 standard.



H264
recording
of
PAL/NTSC

The VCODEC-H264 not only provides H264 compression but can also simultaneously decompress and replay recordings from storage to display.

It allows high quality real-time video and audio capture and compression from PAL/NTSC video sources to disk and simultaneously provides an additional path for uncompressed video for on-screen Preview or optional downstream video analytics. The high performance H264 video data compression and reduced bus utilisation allows up to four VCODEC-H264 cards to be fitted in a PC/104plus system.

Advanced Micro Peripherals Ltd
Cambridge, CB6 2HY, England
Tel (+44) 1353 659500
Tel (+44) 1353 659600
sales@ampltd.com



VCODEC-H264

Single Channel H264 Codec



**Advanced Micro
Peripherals**

THE EMBEDDED VIDEO EXPERTS



Automatic

Scene

Detection

Applications

Solid-State Digital Video Server

Vehicle-based Video Codec

Law Enforcement

Crime Scene Recording

Remote Video Surveillance

Multi-camera Security Application

Asset Monitoring

Traffic Monitoring and Control

Video Acquisition and Analytics

Advanced Micro Peripherals Ltd
Cambridge, CB6 2HY, England
Tel (+44) 1353 659500
Tel (+44) 1353 659600
sales@ampltd.com



VCODEC-H264

Single Channel H264 Codec



**Advanced Micro
Peripherals**

THE EMBEDDED VIDEO EXPERTS



Text and graphics

overlay on

preview and

recording

Features

1 x D1 size H264 Encode at full frame rate

H264 Decode/Playback

Text Overlay: Time, Date stamp etc

Video Preview to system VGA, PAL/NTSC

Up to 4 VCODEC-H264 cards per system

Drivers for Win-NT/2000/XP-E, Linux, QNX

Advanced Micro Peripherals Ltd
Cambridge, CB6 2HY, England
Tel (+44) 1353 659500
Tel (+44) 1353 659600
sales@ampltd.com



Video Recording Modes

The VCODEC-H264 supports recording up to four video inputs as a single H264 file as if they were coming from a single video source. There is no separation and the resulting H264 file can be played as a single H264 stream by the VCODEC-H264 or appropriate hardware/software decoders.

I/P Frame Encoding

The VCODEC-H264 supports encoding of both I and P frames. Encoding of only I frames is also supported. The VCODEC-H264 supports any number of P-frames between successive I-frames. The VCODEC-H264 also supports automatic scene change

detection that inserts an I-frame to improve compression efficiency

Encoding Bit Rate Control

The VCODEC-H264 provides flexible bit rate control by providing two modes: Variable Bit Rate (VBR) and Constant Bit Rate (CBR).

Variable Bit Rate (VBR)

For VBR mode the picture quality is fixed according to a Quantisation value of between 15 and 55. The bit rate varies automatically in reaction to the incoming video to maintain the set quality. VBR is appropriate for storage applications.

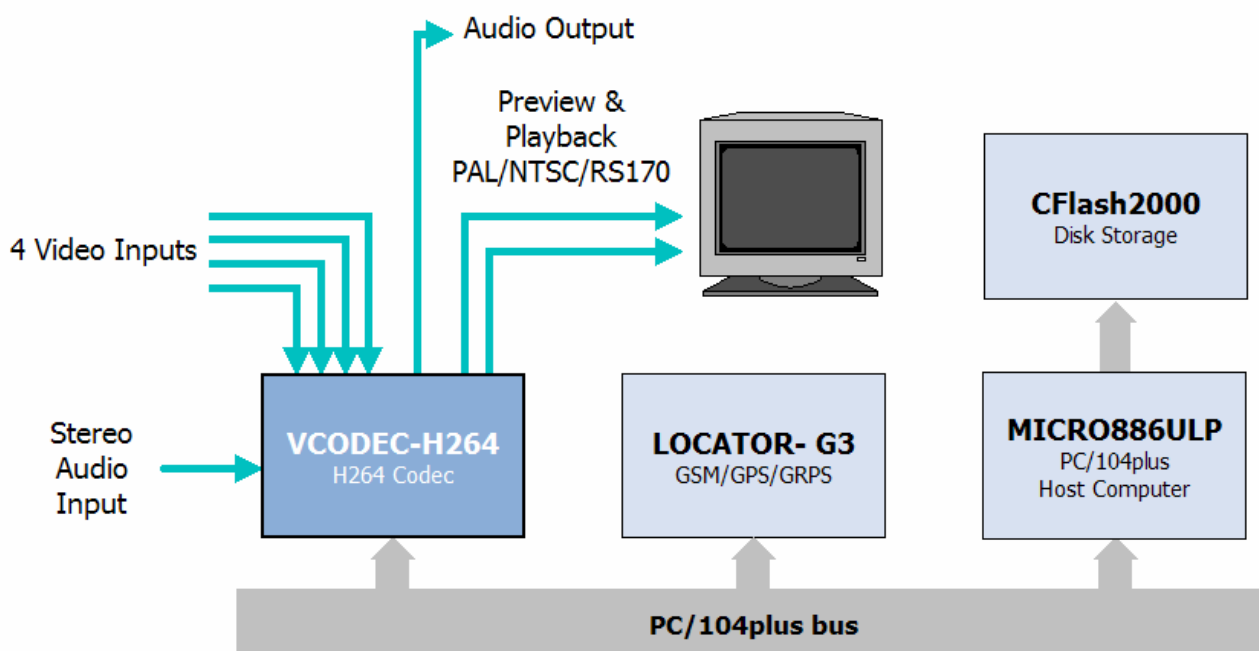

Mobile H264 Record and Playback System

Constant Bit Rate (CBR)

In CBR mode, the average bit rate is fixed and the picture quality is automatically adjusted by the VCODEC-H264 on a frame-by-frame basis to maintain the preset average bit rate. CBR is of particular benefit where video needs to be streamed over a fixed-bandwidth link.

Motion Detection and Event Triggers

The VCODEC-H264 supports automatic motion detection. Motion detection parameters such as regions of interest and frame difference threshold can be configured under software control.

Using the motion-detection feature the VCODEC-H264 can be operated in a baby-sitting mode where recording is committed to disk only when scene motion event is detected, to make most efficient use of disk storage.

Software for the VCODEC-H264 allows recording of pre-trigger, on-trigger and post-trigger events.

Uncompressed Video Preview

The VCODEC-H264 provides a secondary video path allowing the video being recorded to be streamed across the PC/104plus bus to the host system's VGA buffer for video previewing.

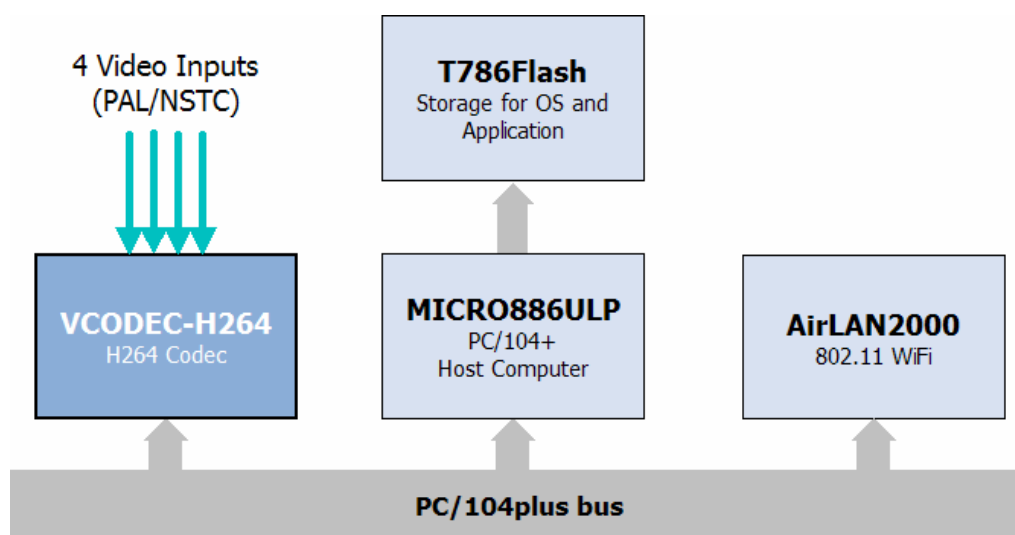

Wireless Video Telemetry System

VCODEC-H264

Single Channel H264 Codec

Operation Summary

The Preview output can also be used to view an alternate video source while recording other inputs. The Preview information is also available as a composite PAL/NTSC output suitable for driving a PAL/NTSC or RS170 display device.

The uncompressed video, in RGB or YUV format, is available to downstream processes and may be used in further image processing applications.

OSD Video Text Overlay

The VCODEC-H264 has a bit-mapped graphic overlay feature which allows text and graphics to be overlaid on incoming video

prior to recording. This a useful feature for applying real-time annotation and labelling to Preview and H264 recordings.

The VCODEC-H264 provides various layers of overlay such as character/bitmap, box overlay and mouse pointer which can be overlaid on Preview and Record paths independently.

Video source information such as camera reference, location, time and date stamp, etc can be overlaid on both preview and recordings.

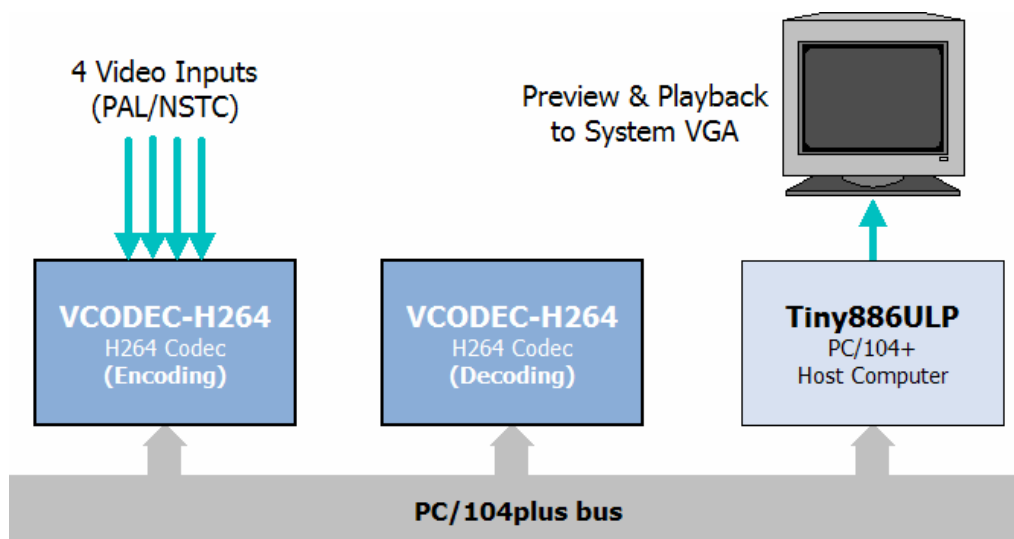

Full Duplex Video Recording System

VCODEC-H264

Single Channel H264 Codec

Operation Summary

H264 Decode and Playback

The VCODEC-H264 supports decoding and playback of H264 files from storage to the host system's display screen. Maximum image size of decoded video is 720 x 480 (NTSC) or 720 x 576 (PAL). Audio data which is part of the original recording is also decoded and played back in synchronisation with the video. In addition to playback to the system's VGA device, the VCODEC-H264

provides a composite PAL/NTSC playback output suitable for directly driving a PAL/NTSC or RS170 display device.

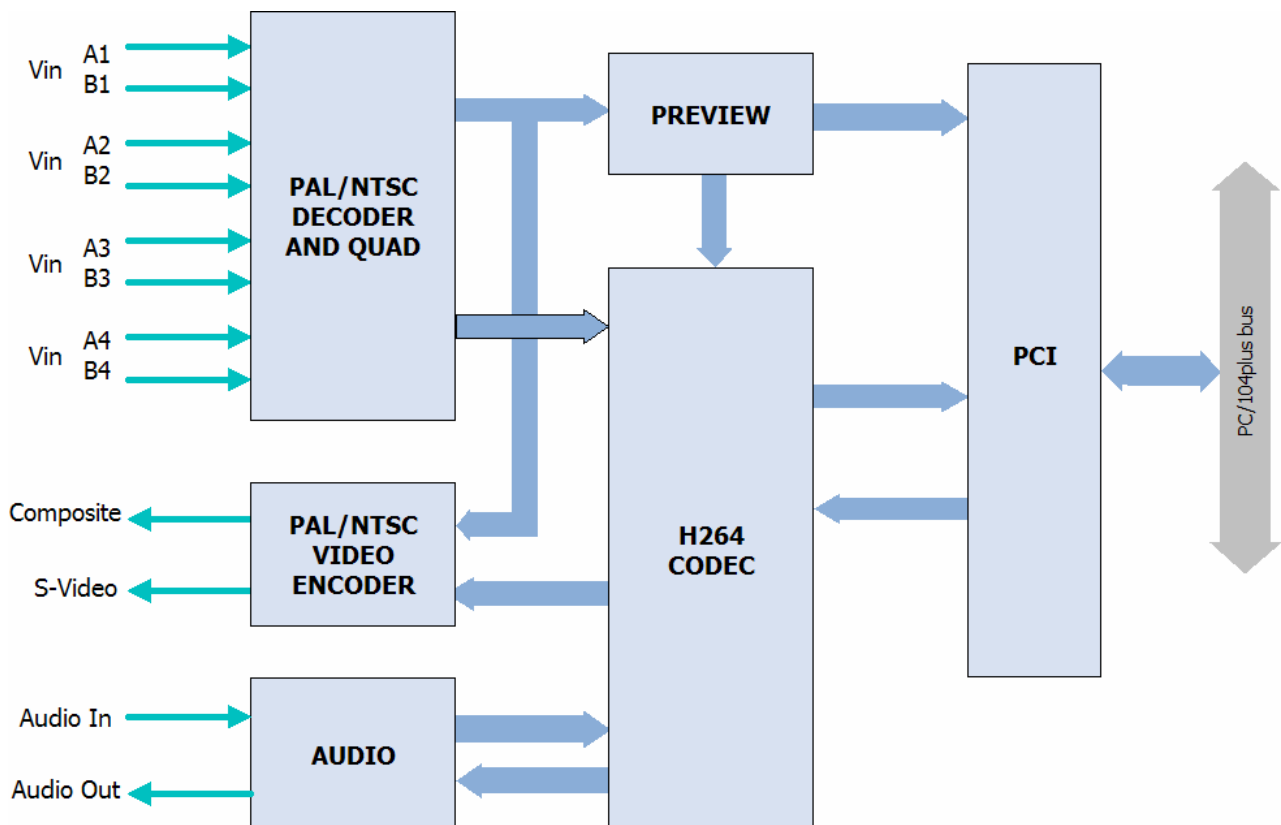

VCODEC-H264 Block Diagram

PC/104plus Bus Interface

- Compliant with PCI Rev 2.1
- 132MBytes/sec bandwidth at 33.33 MHz bus speed
- Live H264 capture to memory or disk
- Concurrent H264 Capture and live preview

Analogue Video Input

- Up to 4 concurrent composite PAL or NTSC video input channels
- Two input video multiplexer per Channel (up to 8 cameras)
- Four 10-bit Analogue-to-Digital converters
- Anti-aliasing filters on inputs

Video Input Formats

- Standard CCIR601-NTSC, CCIR-PAL
- NTSC-M, NTSC-Japan
- PAL-B, PAL-D, PAL-G, PAL-H, PAL-I, PAL-M, PAL-N

Video Input Adjustments

- Contrast (or luma gain) adjustable from 0 - 200% of original value
- Saturation (or chroma gain) adjustable from 0 - 200% of original value
- Hue (or chroma phase) adjustable from -180 to +180
- Brightness (or luma level) can be adjusted from 0 - 255 steps

Audio Input

- High-quality stereo input
- Provides Audio/Video Synchronisation

Video Encoding

- H264 Video Encoding (ISO/IEC 14496-10, Baseline and Main Profile)
- 1 channel NTSC full D1 (720 x 480) at 30fps
- 1 channel PAL full D1 (720 x 576) at 25fps
- Supports I, P and B Frame Compression
- Supports Variable Bit Rate (VBR)
- Supports Constant Bit Rate (CBR)

Audio Encoding

- MPEG1 Layer2 at up to 384KBits/sec
- AAC-LC at upto 384KBits/sec

Video Decoding / Playback

- Real-time H264 Video Decoding
- ISO/IEC 14496-10, H264 Baseline and Main profile
- Playback to Composite PAL/NTSC output

Uncompressed Video Path

- Real-time Preview to host VGA display
- Preview to Composite PAL/NTSC output
- Optional uncompressed RGB/YUV for downstream applications

Motion Detection

1350 (NTSC) or 1620 (PAL) detection blocks
Masking of areas not required for motion detection
Adjustable sensitivity

System Requirements

x86 PC-Compatible PC/104+ Computer
PCI or AGP Display (if Video Preview to host is required)
Spare REQ/GNT on PC/104+ Bus
3.3V or 5V signalling PC/104+ bus

Miscellaneous

Single +5V at less than 1.75A
Operating temp 0 °C to 60 °C or -40 °C to +85 °C (extended temp option)
Standard 3.6 x 3.8in PC/104plus form factor

Software Drivers

Drivers for Windows-NT/2000/XP, Linux, QNX
Sample video recording application in C/C++ source code

Related Products

VCH264-VTelemetry Low Latency Video Telemetry SDK
VCH264-VStream RTSP Video Streaming SDK

Ordering Information

VCODEC-H264 H264 Video Codec (0 to 60 °C)
VCODEC-H264-Ext H264 Video Codec (-40 °C to +85 °C)

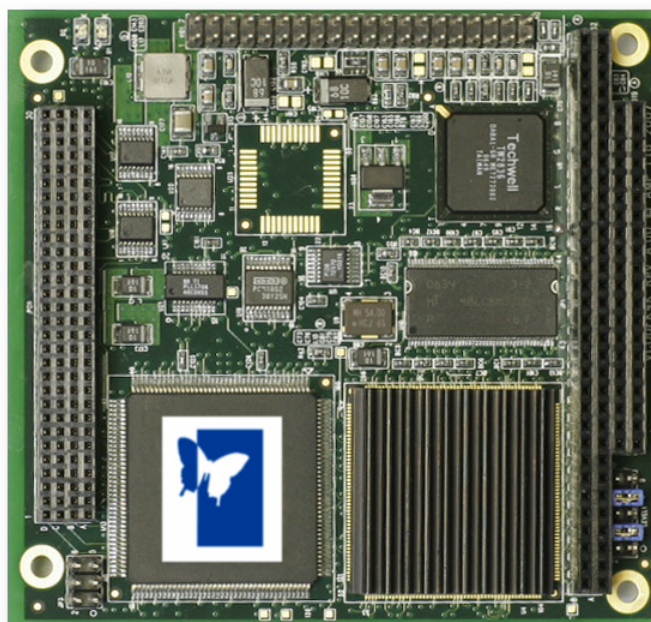

VCODEC-H264